

**Proceedings of the 19th International Symposium on the
Packaging and Transportation of Radioactive Materials
PATRAM 2019
August 4-9, 2019, New Orleans, LA, USA**

NAC's OPTIMUS™ Packaging for Intermediate Level Wastes

Steven Sisley
NAC International

Jeff England
NAC International

ABSTRACT

NAC OPTIMUS™ packagings are a Type B(U)F-96 transportation package designed for maximum flexibility and cost-efficiency to support shipment of a wide range of challenging wastes and materials. It is a small, modular packaging meeting DOT weight limits for road transport. Contents can be accommodated in multiple configurations including standard drums of up to 110 gallons in size. The packagings also accommodate unique waste contents and fuel designs where cost-effective packaging options have been a challenge. The packagings have a simplicity of design and operational flexibility to meet both IAEA and U.S. NRC Type B requirements. Flexibility is assured by the modular design for containment, shielding and criticality control. The containment boundary design permits adaptability to content requirements by relying on interchangeable internal components or dunnage.

The OPTIMUS™ packaging utilizes the same cask containment vessel (CCV) in the OPTIMUS™-H and OPTIMUS™-L. The OPTIMUS™-L is a lightweight transportation packaging with a capability of up to ten (10) OPTIMUS™-L packages per legal-weight truck shipment. The OPTIMUS™-H has an Outer Shield Vessel (OSV) made of ductile cast iron and Impact Limiters (IL) with a higher payload capacity than the OPTIMUS™-L. The large cavity size of the CCV, can accommodate standard drums up to 110-gallons, combined with the small size and modularity of the OPTIMUS™ packaging provides unmatched flexibility for the user.

OPTIMUS™ packagings can accommodate more radioactive waste in each drum (up to an FGE limit of 390 g ²³⁹Pu) than larger packages can in 10 drums. OPTIMUS™ contents include low level waste, mixed low-level waste, irradiated fuel waste and intermediate level waste. These contents can include aerosol cans with compressed gas and liquified gas propellants and standard DOT 3E lecture bottles for shipment to treatment facilities.

In this paper, NAC provides a technical overview of the OPTIMUS™ packagings and identifies the design features and technology advancements making the OPTIMUS™ product line a readily adaptable and flexible solution for packaging processing facilities, reactor and decommissioning wastes. The system enables the integration of these wastes into the existing waste management system process and disposition infrastructure.

INTRODUCTION

The OPTImal Modular Universal Shipping (OPTIMUS™) package product line includes two different package designs; the OPTIMUS™-H and OPTIMUS™-L, shown in Figure 1. Both

packages are designated Type B(U)-F and designed to satisfy the most limiting requirements of 10 CFR 71 [1] and IAEA SSR-6 [2]. The OPTIMUS™-H packaging is used to transport radioactive materials (RAM) that require significant shielding for gamma radiation, whereas the standard OPTIMUS™-L packaging is used to transport RAM requiring minimal gamma shielding. However, the large cavity size and payload weight limit of OPTIMUS™-L allows for the addition of shield inserts inside the CCV to accommodate content with increased activities. This paper describes the general physical attributes, lifting and tiedown attachments, structural, thermal, containment, and shielding features, and contents of the OPTIMUS™ packagings.

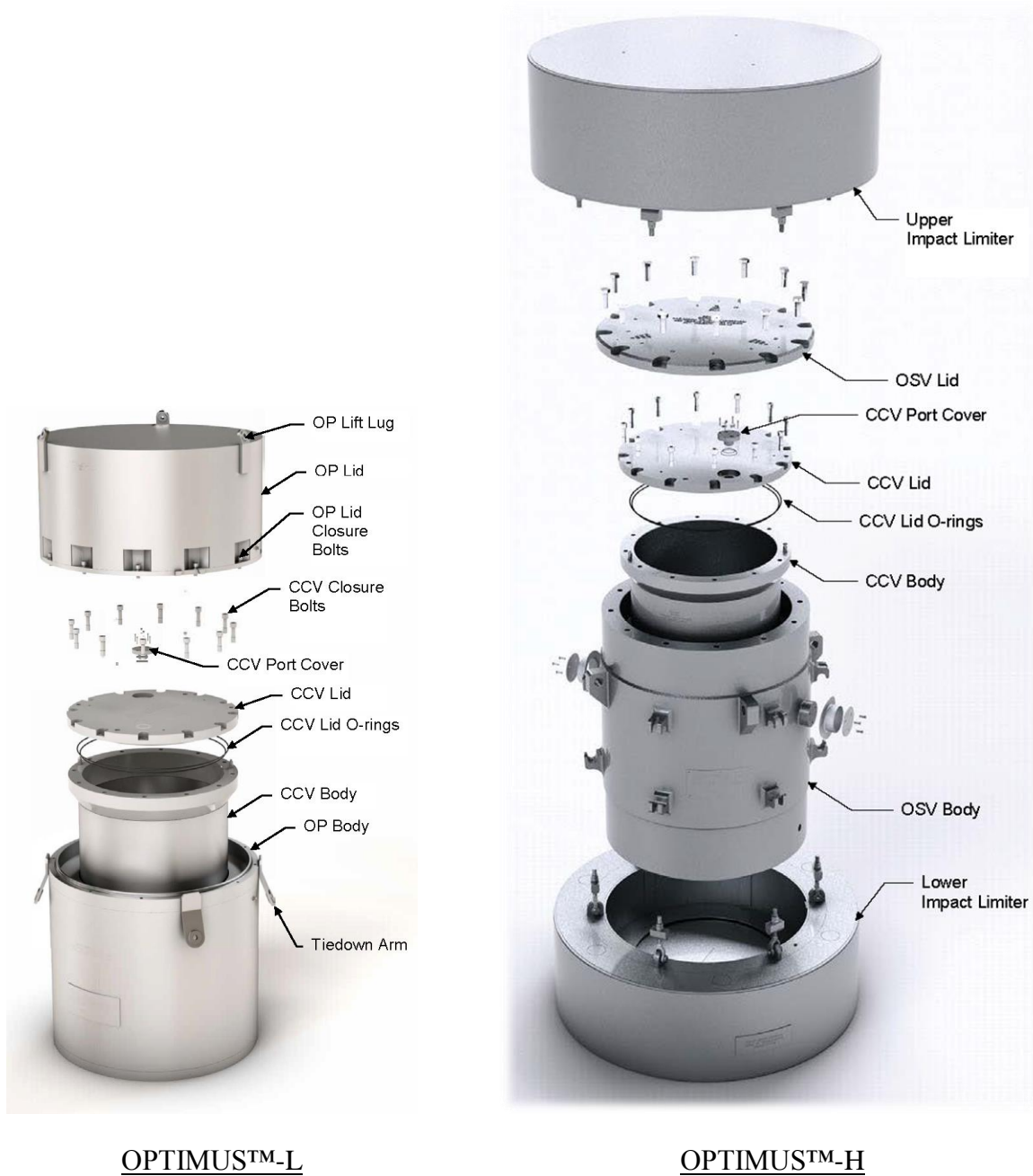

Figure 1. OPTIMUS™ Packagings

GENERAL PACKAGING DESCRIPTIONS

The OPTIMUS™ packaging product line currently includes two different Type B(U)-F packagings; OPTIMUS™-H and OPTIMUS™-L. Both the OPTIMUS™-H and OPTIMUS™-L packages use the same Cask Containment Vessel (CCV). However, the outer packaging of the OPTIMUS™-H and OPTIMUS™-L differ due to shielding requirements for the intended contents. The outer packaging of the OPTIMUS™-H, designed to accommodate high-activity contents, consists of a thick-walled Outer Shield Vessel (OSV) and an Impact Limiter System (ILS), whereas the outer packaging of the OPTIMUS™-L consists of a stainless steel drum-like assembly filled with rigid polyurethane foam for impact and thermal protection. The physical attributes of the OPTIMUS™-H and OPTIMUS™-L packages are summarized in Table 1.

TABLE 1. OPTIMUS™ Packaging Physical Attributes

Packaging Physical Attributes	Packaging Design	
	OPTIMUS™-H	OPTIMUS™-L
Outer Dimensions ⁽¹⁾	Ø188.5 cm x 211.3 cm high (Ø74.2 in. x 83.2 in. high)	Ø124.5 cm x 177.8 cm high (Ø49 in. x 70 in. high)
Cavity Dimensions	Ø82.6 cm x 119.4 cm high (Ø32.5 in. x 47.0 in. high)	Ø82.6 cm x 115.6 cm high (Ø32.5 in. x 45.5 in. high)
Packaging Tare Weight	11,202 kg (24,700 lbs.)	2,721 kg (6,000 lbs.)
Max. Contents Weight	3,311 kg (7,300 lbs.)	1,429 kg (3,150 lbs.)
Gross Weight ⁽²⁾	~11,338 to 14,512 kg (~25,000 to 32,000 lbs.)	~2,847 to 4,172 kg (~6,300 to 9,200 lbs.)
Gamma Shield Thickness ⁽³⁾	≥ 20.3 cm (8.0 in.) iron/steel	≥ 3.3 cm (1.3 in.) steel

Notes:

1. Outer dimensions excluding lifting and tiedown protrusions.
2. Range based on variation of contents weight.
3. Shielding inserts can be added for supplemental shielding of contents, as required.

The OPTIMUS™-H and OPTIMUS™-L packagings are designed to ship similar contents with different activities, so it is likely users may require both OPTIMUS™-H and OPTIMUS™-L packagings for large shipping campaigns. By using a common CCV design in both the OPTIMUS™-H and OPTIMUS™-L packagings, operating procedures for loading contents, CCV closure, and unloading contents are largely standardized, simplifying operations for users operating both OPTIMUS™-H and OPTIMUS™-L packagings. In addition, the use of a common CCV design allows for operational flexibility and interchangeability of the CCV between packages, with clear economic benefits for users operating both OPTIMUS™-H and OPTIMUS™-L packages.

The outer packaging of the OPTIMUS™-H and OPTIMUS™-L are significantly different due to shielding requirements for the intended contents. The outer packaging of the OPTIMUS™-L consists of a stainless steel drum-like assembly that is filled with rigid polyurethane foam for impact and thermal protection, whereas the outer packaging of the OPTIMUS™-H, which is designed to accommodate high-activity contents, consists of a thick-walled Outer Shield Vessel (OSV) and an Impact Limiter System (ILS). Because of the differences in the outer packaging, the OPTIMUS™-L has a much smaller outer envelope and gross weight than the OPTIMUS™-H. As shown in Table 1, OPTIMUS™-L has external dimensions of Ø124.5 cm (Ø49.0-inch) by 177.8 cm (70.0-inch) high and maximum gross weight of only

4,172 kg (9,200 pounds) compared to Ø188.5 cm (Ø74.2-inches) by 211.3 cm (83.2-inch) high and 14,512 kg (32,000 pounds) for the OPTIMUS™-H. The smaller size and weight of the OPTIMUS™-L package result in significant improvement in operational efficiencies for lower activity contents that larger packages. For example, OPTIMUS™-L packages can be loaded and pre-staged for shipment to minimize wait times for the driver and transport equipment, which reduces shipping costs. In addition, the per-drum content weight, decay heat, and fissile gram equivalent of RAM is much higher than that of larger transportation packages.

Loading operations for the OPTIMUS™-L package differ by content and facility type. Typical contents of the OPTIMUS™-L package with low surface dose rates may be loaded directly into the CCV. Contents with high surface dose rates may require loading via a shielded transfer cask and/or transfer adapter or via remote operations. The OPTIMUS™-L package may be loaded while mounted on the trailer deck, or it may be removed from the trailer for loading operations performed inside a facility. The modularity of the OPTIMUS™-L packaging provides maximum flexibility for operations.

LIFTING FEATURES

Unlike most other Type B(U) packages used to transport similar RAM contents, the OPTIMUS™ packagings are relatively small and lightweight, simplifying lifting and handling operations. The primary mode of lifting and handling the OPTIMUS™ package is by forklift using a pallet, as shown in Figure 2. The pallet allows the OPTIMUS™ packages to be quickly and easily loaded onto or unloaded from a trailer outside the secure area of a facility without the need for a mobile crane and it eliminates the need to bring the tractor and trailer into the facility's secure area.

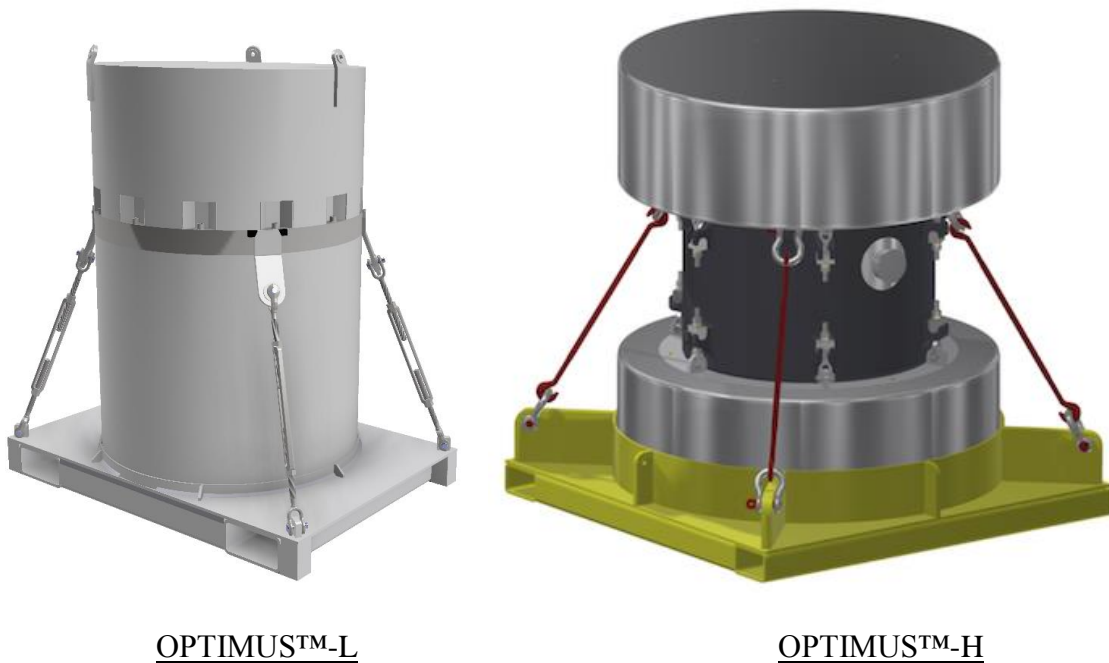

Figure 2. OPTIMUS™ Packaging Secured to Pallet

The loaded OPTIMUS™-L package, with the pallet and tiedowns attached, may also be lifted from the three (3) lifting lugs attached to the OP lid using standard rigging. With the upper impact limiter

removed, the loaded OPTIMUS™-H package may also be lifted either by the two (2) lifting trunnions or by two (2) diametrically opposed tiedown lugs on the OSV body. The lifting attachments are designed to provide minimum factors of safety of six (6) against yield strength and ten (10) against ultimate tensile strength in accordance with the requirements of ANSI N14.6 [3].

The loaded CCV assembly is lifted from the three (3) threaded holes located on the top surface of the CCV lid, into which swivel hoist rings are installed and standard rigging is attached. The CCV lifting attachments are designed to provide minimum factors of safety of six (6) against yield strength and ten (10) against ultimate tensile strength in accordance with the requirements of ANSI N14.6 [3].

TIEDOWN FEATURES AND SHIPPING CONFIGURATIONS

The OPTIMUS™-L package is designed to be secured to a pallet using the four (4) tiedown arms attached to the OP base bolt flange, as shown in Figure 2. The pallets are then placed onto a trailer deck and secured in accordance with applicable transport regulations. The OPTIMUS™-L packages may also be secured directly to a trailer deck if a pallet is not used. The 127 cm (50-inch) wide pallet is sized to permit two (2) OPTIMUS™-L packages to be placed over the width of a standard 259 cm (8'-6") trailer deck. Up to ten (10) OPTIMUS™-L packages are allowed per shipment, as shown in Figure 3. For typical contents weighing approximately 500 pounds, ten (10) OPTIMUS™-L packages will satisfy the weight limits for a LWT shipment. For heavier contents, the number of packages may be reduced to stay within LWT limits, or shipping permits may be obtained.

The OPTIMUS™-H package is designed to be secured to a pallet using the four (4) tiedown lugs located on the outside of the OSV body, as shown in Figure 2. The pallets are then placed onto a trailer deck or inside a 20-foot ISO container, as shown in Figure 3, and secured in accordance with applicable transport regulations. The OPTIMUS™-H packages may also be secured directly to a trailer deck if a pallet is not used. For typical contents weighing, two (2) OPTIMUS™-H packages can be shipped on a trailer as a LWT shipment.



OPTIMUS™-L

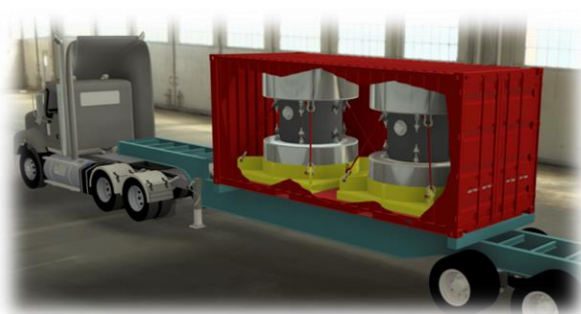

OPTIMUS™-H

Figure 3. Typical OPTIMUS™ Package Transport Configurations

ENERGY-ABSORBING FEATURES

The OPTIMUS™-L OP lid and base assemblies are designed to crush and absorb energy under NCT and HAC free drops to limit the shock loads imparted to the CCV and contents. The OP base and lid are both constructed from stainless steel shells that fully encase energy absorbing closed-cell polyurethane foam core components to create a sealed cavity to protect the foam core from the external environment. The outer shells and outer end plates of the OP lid and base are constructed from 0.5 cm (3/16 inch) thick

stainless steel plate and inner shells are constructed from 14-gauge (0.2 cm (0.0751-inch) thick) stainless steel sheet. The OP shells are designed to plastically deform under NCT and HAC free drop conditions, but not fail in any manner that would expose the OP foam to the ambient environment.

The OP lid and base foam cores are comprised of 80 kg/m³ (5 pcf) and 384 kg/m³ (24 pcf) closed-cell polyurethane foam for optimal performance in the NCT and HAC free drop tests. The 80 kg/m³ (5 pcf) foam cores used in the top end of the OP lid is not crushed under any NCT or HAC free drop conditions but provides thermal protection of the CCV lid O-ring seals for the HAC thermal test. All energy absorption is provided by the 384 kg/m³ (24 pcf) foam core used in the corner and overhang regions of the OP lid and base. Shear rings attached to the top and bottom inner end plates provide backing support for the corner foam under side, corner, and oblique drop impacts.

The OPTIMUS™-H impact limiter system (ILS) consists of an upper and lower limiter attached to the OSV using a set of brackets cast into the OSV body along with lugs integrated into each impact limiter connected using clevis style shackles. The impact limiters are symmetric and interchangeable, each consisting of stainless steel shells encapsulating rigid closed-cell polyurethane foam. Each impact limiter has a pocket on the inside that fits over the respective end of the OSV. Both the upper and lower impact limiters include removable lugs that are used to lifting the impact limiter but may not be used to lift the package or as tie-down attachments for transport. A drain feature is also included that allows any water entering the annular gap between the OSV and the and impact limiter to drain. For the top impact limiter, the drain shall be capped to prevent water intrusion.

THERMAL FEATURES

The OPTIMUS™-L packaging includes thermal insulation in the OP lid that helps control the temperature of the packaging components under NCT and HAC. A 0.6 cm (¼-inch) thick layer of ceramic fiber insulation is attached to the inner surface of the OP lid outer end plate to minimize heating of the overpack foam from insulation. This maintains the temperature of the foam under NCT below the lower-bound temperature assumed for the foam stress-strain properties used in the drop analyses. In addition, this feature minimizes the heating of the CCV closure O-ring seals during the HAC fire.

CONTAINMENT FEATURES

The OPTIMUS™ packaging containment system, designed to a “leaktight” containment criterion per ANSI N14.5 [4], is formed by CCV body (cylindrical shell, bottom plate, bolt flange, and all associated welds), CCV lid and its closure bolts and containment O-ring seal, and the port cover and its closure bolts and containment O-ring seal.

The CCV lid is a stepped plate secured to the CCV body by twelve (12) high strength stainless steel custom CCV lid bolts and sealed by an elastomeric O-ring. The design of the CCV lid prevents shear loading of the CCV lid bolt under NCT free drop, HAC free drop, and HAC puncture tests. The CCV lid’s inner plug, which fits tightly inside the top opening of the CCV body, prevents significant lateral movement of the CCV lid relative to the CCV body bolt flange to prevent shear loading of the CCV lid bolts. The CCV lid bolts are 2.5 cm (1-inch) diameter socket head cap screws that are machined to create captured bolts. The CCV lid has twelve (12) bolt holes with scalloped pockets in which the CCV lid bolt heads are recessed and protected from impact loads.

For transport the CCV port cover is installed and sealed by an elastomeric O-ring. The CCV port cover is secured to the CCV lid by four (4) 0.6 cm (¼-inch) diameter stainless steel socket head cap screws. The CCV port cover is recessed in a pocket within the CCV lid and protected from shear loading due to free drop and puncture tests.

SHIELDING FEATURES

Gamma shielding on the OPTIMUS™-L packaging is provided by stainless steel plates forming the CCV and OP inner and outer shells. The packaging radial surfaces include the CCV 2.5 cm (1-inch) thick stainless steel shell, the 0.2 cm (0.0751-inch) thick (14-gauge) OP inner shells, and a 0.5 cm (3/16 inch) thick OP outer shell, for a combined steel thickness of 3.2 cm (1.26 inches). Additional shielding thickness is provided on the top and bottom ends of the package.

Gamma shielding on the OPTIMUS™-H packaging is provided by stainless steel plates forming the CCV, the ductile cast iron OSV, and the impact limiter inner and outer shells. The packaging radial surfaces include the CCV 2.5 cm (1-inch) thick stainless steel shell and 17.8 cm (7-inch) thick OSV wall. Equivalent shielding is provided on the top and bottom ends of the package.

Shield inserts will be added for future contents requiring additional gamma shielding or neutron shielding. With the OPTIMUS™ packaging's large content weight limits and large cavity size, it has the ability to accommodate a wide range of contents with higher source terms.

CONTENTS

The current contents of the OPTIMUS™ package include intermediate level waste (ILW) and irradiated fuel waste.

All waste contents shall be in secondary containers (e.g., drums or boxes). In addition, the contents shall not exceed the fissile gram equivalent (FGE) limits for plutonium contents or the Fissile Equivalent Mass (FEM) limits for low-enriched uranium (LEU) contents from Table 2.

TABLE 2. OPTIMUS™ Packaging Contents

Content Type	Content Limits	
	OPTIMUS™-H	OPTIMUS™-L
ILW and TRU Waste	≤ 390g Pu-239 ⁽¹⁾	≤ 395g Pu-239 ⁽²⁾
LEU	≤ 2,268 kg (5,000 lb.), 0.96 wt% U-235 ⁽³⁾	≤ 1,134 kg (2,500 lb.), 0.89 wt% U-235

Notes:

- ¹ FGE limit shown for hand compacted TRU waste with ≥25g Pu-240 credit. The FGE limit for hand compacted TRU waste with no Pu-240 credit is 335g Pu-235. The FGE limit for machine compacted TRU waste is 250g Pu-239.
- ² FGE limit shown for hand compacted TRU waste with ≥25g Pu-240 credit. The FGE limit for hand compacted TRU waste with no Pu-240 credit is 340g Pu-239. The FGE limit for machine compacted TRU waste is 250g Pu-239.
- ³ Enrichment limit shown with particle size restriction of ≤ 0.1 cm and/or ≥ 8.0 cm. Enrichment limit without particle size restriction is 0.80 wt% U-235.

Shoring must be placed between loose fitting contents and the CCV cavity to prevent excessive movement during transport. The shoring may be made from any material that does not react negatively with the packaging materials or contents.

The large cavity size and high content weight limits of both the OPTIMUS™-L and OPTIMUS™-H packages allow the addition of payload shield liners (PSLs) through future amendments for higher activity contents. PSLs may be made from various materials and sizes, depending on the type and amount of

shielding required. Aside from attachments for lifting, PSL do not have any other noteworthy operational features.

OPTIMUS™ REGULATORY APPROVALS

The OPTIMUS™-H application was submitted to CNSC in July 2018 and it is anticipated that CNSC will issue the certificate by the end of 2019. The OPTIMUS™-L application was submitted to CNSC in March 2019 and it is anticipated that the certificate will be issued in early 2020. Submittals of OPTIMUS™-H and OPTIMUS™-L applications to the U.S. Department of Energy (DOE) are expected in the near future.

REFERENCES

1. U.S. Nuclear Regulatory Commission (NRC), *Code of Federal Regulations Title 10, Part 71- Packaging and Transportation of Radioactive Material*, 2017.
2. International Atomic Energy Agency (IAEA), *Regulations for the Safe Transport of Radioactive Material, Specific Safety Requirements No. SSR-6*, 2012 Edition.
3. ANSI N14.6, *Special Lifting Devices for Shipping Containers Weighing 10000 Pounds (4500 kg) or More*, American National Standards Institute, Inc., New York, 1993.
4. ANSI N14.5 2014, *American National Standard for Radioactive Materials – Leakage Tests on Packages for Shipment*, American National Standards Institute, Inc., June 19, 2014.