

## SPENT FUEL TRANSPORTATION RISK ASSESSMENT: ROUTINE TRANSPORTATION

Ruth F. Weiner  
Sandia National Laboratories\*

### ABSTRACT

The RADTRAN model for calculating radiation doses is based on the well-understood behavior of ionizing radiation. Absorption of ionizing radiation depends on the energy and type of radiation and on the absorbing material. The casks that are used to transport spent nuclear fuel have walls that absorb most of the emitted ionizing radiation and thereby shield the public and the workers. For routine transportation, RADTRAN models the cask as a sphere and assumes that the longest dimensions of the trailer or railcar carrying the cask is the same as that of the cask. The dose rate in Sv/hour at one meter from the cask is modeled as a virtual source at the center of a sphere whose diameter is the longest dimension of the actual spent fuel cask.

People who live along the cask's route and the people in vehicles that share the route are exposed to external radiation from the cask. The dose to workers and the public from a cask during routine transportation depends on the time that the workers or public are exposed to the cask, the distance from the cask, and the cask's external radiation. When the vehicle carrying the cask is traveling along the route, the faster the vehicle goes, the less exposure to anyone along the vehicle's route. Therefore, an individual member of the public receives the largest dose from a moving vehicle when he or she is as close as possible to the vehicle, and the vehicle is traveling as slowly as possible. In the present analysis, these doses are in the range of four to seven nanosieverts. Collective doses along the route depend on the size of the exposed population. In this study, such doses were of the order of 0.1 person-millisieverts. The appropriate comparison between the collective dose from a shipment of spent fuel is not a comparison between the radiation dose from the shipment and zero dose, but between the background radiation dose in the presence and absence of a shipment; e.g., 8.810096 person-Sv if there is a shipment and 8.81000 person-Sv if there is no shipment.

### INTRODUCTION

The current version of the RADTRAN computer code (Taylor and Daniel, 1977), RADTRAN 6, is used to estimate risks from routine<sup>†</sup> transportation of spent nuclear fuel (SNF). Sandia National Laboratories initially developed RADTRAN for the NRC's NUREG-0170 risk assessment. During the past several decades, the calculation method and RADTRAN code have improved to stay current with computer technology and supporting input data have been collected and organized. The basic RADTRAN analysis approach has not changed since the

---

\* Sandia National Laboratories is a multi-program laboratory managed and operated by Sandia Corporation, a wholly owned subsidiary of Lockheed Martin Corporation, for the U.S. Department of Energy's National Nuclear Security Administration under contract DE-AC04-94AL85000

<sup>†</sup> The term "routine transportation" is used throughout this document to mean incident- or accident-free transportation.

original development of the code, and the risk assessment method used in the RADTRAN code is accepted worldwide; about 25 percent of the 500 RADTRAN users are international.<sup>‡</sup>

RADTRAN 6.0, integrated with the input file generator RADCAT (Neuhauser et al., 2000,<sup>§</sup> Weiner et al., 2009) is the version used in this study. The incident-free module of RADTRAN, the model used for the analysis in this paper, was validated by measurement (Steinman et al., 2002), and verification and validation of RADTRAN 6.0 are documented in Dennis et al., 2008.

This paper discusses risks to the public and workers when transportation of casks containing spent fuel takes place without incident and the transported casks are undamaged. Non-radiological vehicular accident risk, which is orders of magnitude larger than the radiological transportation risk, was not analyzed in this study.

## RADIATION EMITTED DURING ROUTINE TRANSPORTATION

In certifying spent fuel casks for transportation, the U.S. Nuclear Regulatory Commission (NRC) allows some external emission of ionizing radiation. The regulatory maximum external dose rate is  $10^{-4}$  Sv per hour (10 mrem per hour) at two meters from the external surface of the transportation cask (10 CFR 71.47)<sup>\*\*</sup>. Although both gamma and neutron radiation are included, for spent uranium-based fuel, the gamma radiation typically dominates the external dose rate.

This dose rate is about 0.00014 Sv/hour (14 mrem per hour) at one meter (40 inches) from a cask four to five meters (13 to 17 feet) long. The external radiation doses from the casks in this study, determined from values reported in the cask SARs, are shown in Table 1 (Holtec, 2004; NAC, 2002; General Atomics, 1998).

**Table 1. External Radiation Doses from the Casks in this Study**

	Truck-DU	Rail-Lead	Rail-Steel
Transportation mode	Highway	Rail	Rail
Dose rate Sv/h (mrem/h) at 1 m (40 inches)	0.00014 (14)	0.00014 (14)	0.000103 (10.3)
Gamma fraction	0.77	0.89	0.90
Neutron fraction	0.23	0.11	0.10

The calculated radiation dose to workers and members of the public from a routine shipment is based on the external dose rate at one meter from the spent fuel cask as shown in Figure 1. This dose rate, when expressed in mrem per hour (or mSv per hour times 100), is numerically equal to the transport index (TI).

<sup>‡</sup> The currently registered RADTRAN users are listed on a restricted-access Web site at Sandia National Laboratories.

<sup>§</sup> Neuhauser et al. (2000) is the technical manual for RADTRAN 5 and is cited because the basic equations for the incident-free analyses in RADTRAN 6 are the same as those in RADTRAN 5. The technical manual for RADTRAN 6 is not yet available.

<sup>\*\*</sup> The wording of the regulation is actually “two meters from a plane surface perpendicular to the outside edge of the vehicle carrying the cask.” The vehicle, in the case of SNF transportation, is the trailer on which the cask is mounted. The RADTRAN calculation takes no credit for any offset of the cask from the trailer edge.

## THE RADTRAN MODEL OF ROUTINE, INCIDENT-FREE TRANSPORTATION

For analysis of routine transportation, RADTRAN models the cask as a sphere with a radiation source at its center and assumes that the dimensions of the trailer or railcar carrying the cask are the same as the cask dimensions. The emission rate of the radiation source is based on the TI instead of a shielding calculation. The radiation source is modeled as a virtual source at the center of the sphere shown in Figure 1 that produces the same TI as the cask. The diameter of this spherical model, called the “critical dimension,” is the longest dimension of the actual spent fuel cask.

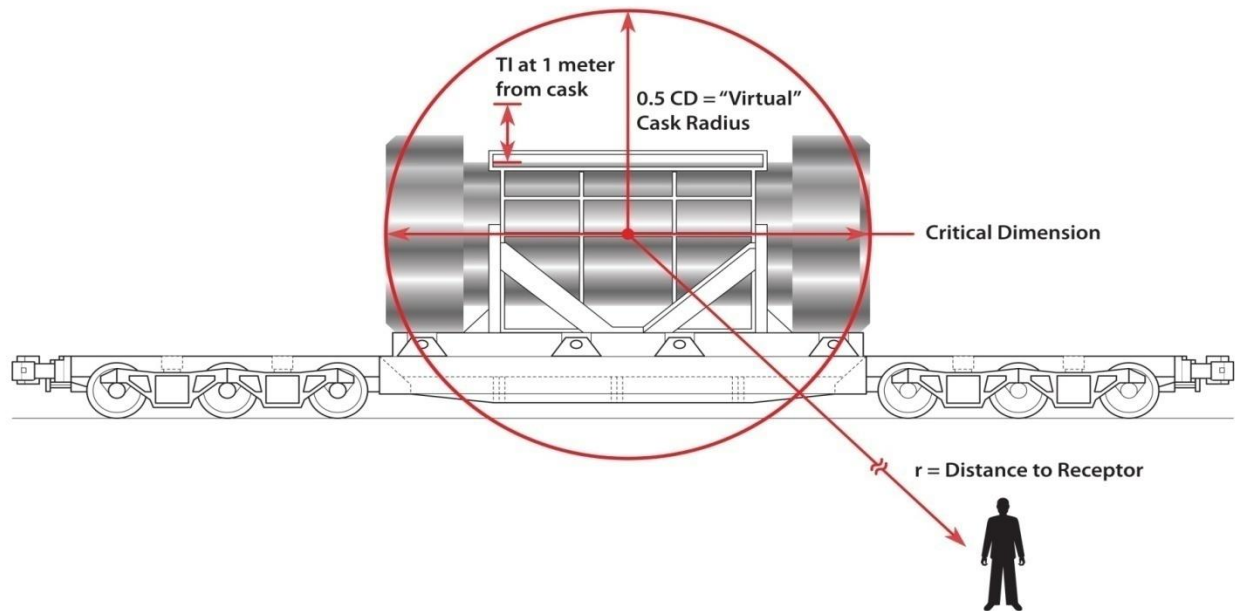

**Figure 1. RADTRAN model of the vehicle in routine, incident-free transportation. The cask in this diagram is positioned horizontally; the critical dimension is the cask length.**

When the distance to the receptor is much larger than the critical dimension, RADTRAN models the dose to the receptor as proportional to  $1/r^2$ . When the distance to the receptor  $r$  is similar to or less than the critical dimension, as for crew or first responders, RADTRAN models the dose to the receptor as proportional to  $1/r$ . The RADTRAN spherical model overestimates the measured dose by a few percent (Steinman et al., 2002).

The dose to workers and the public from a cask during routine transportation depends on the amount of time workers or the public are exposed to the cask, the distance from the cask, the external radiation from the cask, and intervening shielding. When the vehicle carrying the cask is traveling along the route, the dose delivered by the vehicle also depends on the vehicle speed. For trucks and trains carrying spent fuel at a speed of 24 kilometers per hour (kph) (15 miles per hour (mph)) and a distance of 30 meters (approximately 100 feet) are assumed for maximum exposure.<sup>††</sup> Table 2 shows the maximum dose to an individual member of the public under these

<sup>††</sup> Thirty meters is typically as close as a person on the side of the road can get to a vehicle traveling on an interstate highway.

conditions. These doses are about the same as 1 minute of average background:  $6.9 \times 10^{-9}$  Sv ( $6.9 \times 10^{-4}$  mrem).

**Table 2. Maximum Individual In-Transit Doses**

Cask (mode)	Dose, Sv (mrem)
Rail-Lead (rail)	$5.7 \times 10^{-9}$ ( $5.7 \times 10^{-4}$ )
Rail-Steel (rail)	$4.3 \times 10^{-9}$ ( $4.3 \times 10^{-4}$ )
Truck-DU (truck)	$6.7 \times 10^{-9}$ ( $6.7 \times 10^{-4}$ )

When a vehicle carrying a spent fuel cask travels along a route, the people who live along that route and the people in vehicles that share the route are exposed to the external radiation from the cask and sustain a collective dose. A collective dose, sometimes called a population dose, is essentially an average individual dose multiplied by the number of people exposed.\*\*

RADTRAN calculates collective doses along transportation routes by integrating over the width of a band along the route where the population resides and then integrating along the route. Collective doses to people on both sides of the route are included. The exposed population is in a band 770 meters (approximately 0.5 miles) on either side of the route: from 30 meters (100 feet) from the center of the route to 800 meters (0.5 miles). Figure 2 shows how these bands are defined with examples of distances within the bands. Table 3 summarizes the route characteristics.

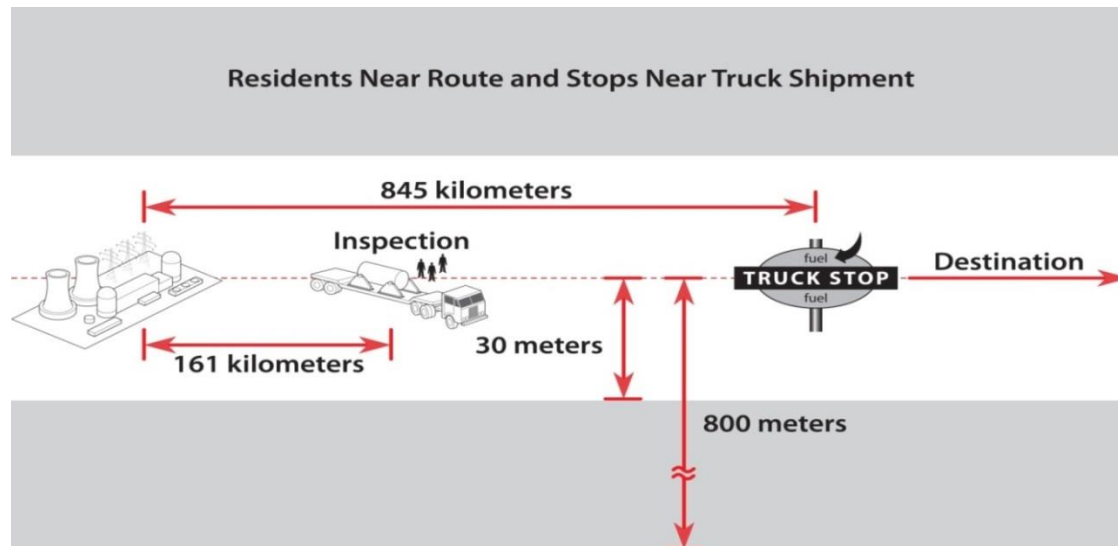

**Figure 2. Diagram of a truck route as modeled in RADTRAN (not to scale)**

Occupants of vehicles that share the route with the radioactive shipment also receive a radiation dose from the spent fuel cask. The collective dose to vehicle occupants depends on the average

\*\* Appendix II of NRC (2012) contains a detailed discussion on the collective dose.

number of occupants per vehicle and the number of vehicles per hour that pass the radioactive shipment in both directions.

**Table 3. Characteristics of Rural, Suburban, and Urban Routes**

	Basis	Highway			Rail		
		Rural	Suburban	Urban	Rural	Suburban	Urban
Population density per km <sup>2</sup> (per mi <sup>2</sup> ) <sup>a</sup>	TRAGIS <sup>h</sup>	0 to 54 (0 to 139)	54 to 1,284 (139 to 3,326)	>1,284 (>3,326)	0 to 54 (0 to 139)	54 to 1,284 (139 to 3,326)	>1,284 (>3,326)
Sidewalk occupant/resident ratio <sup>b,9</sup>	Urban Areas	NA	NA	6	NA	NA	NA
Shielding by buildings <sup>b</sup>	Historic RADTRAN use	0 (outside)	13% (wood)	98.2% (concrete, brick)	0 (outside)	13% (wood)	98.2% (concrete, brick)
U.S. average vehicle speed kph (mph) <sup>c,d</sup>	DOT <sup>i</sup>	108 (67)	108 (67)	102(63)	40 (25)	40 (25)	24 (15)
U.S. average vehicles per hour <sup>b,e</sup>	DOT	1119	2,464	5,384	17	17	17
Occupants of other vehicles <sup>b,f</sup>	DOT	1.5	1.5	1.5	1	1	5

<sup>a</sup> Johnson and Michelhaugh, 2003; <sup>b</sup>Weiner et al., 2009 Appendix D; <sup>c</sup>DOT, 2004a; <sup>d</sup>DOT, 2004b, Appendix D; <sup>e</sup>DOT, 2009 (these are average railcars per hour); <sup>f</sup>DOT, 2008, Table 1-11; <sup>g</sup>Applies only to sidewalks on secondary roads in urban areas; <sup>h</sup>TRAGIS (WebTRAGIS) is a routing code; <sup>i</sup>U.S. Department of Transportation.

The routing code WebTRAGIS (Johnson and Michelhaugh, 2003) provides these combinations of rural, suburban, and urban route segments and populations for each state traversed by a particular route. Various criteria for the route(s) to be determined may be specified including Highway Route Controlled Quantity (HRCQ) criteria, which are used for the 16 truck routes presented within this paper. For population determinations, the user may specify the buffer zone from which the population is calculated. The default buffer zone is 800 meters (on either side of the route) and this default buffer is used in this paper.

The maps in Figures 3 through 6 show the 16 truck and 16 rail routes analyzed in this report. These illustrative routes were selected as representative of possible cross-country transport. The maps are adapted from the output of the routing code WebTRAGIS (Johnson and Michelhaugh, 2003).

## Maine Yankee NP Routes

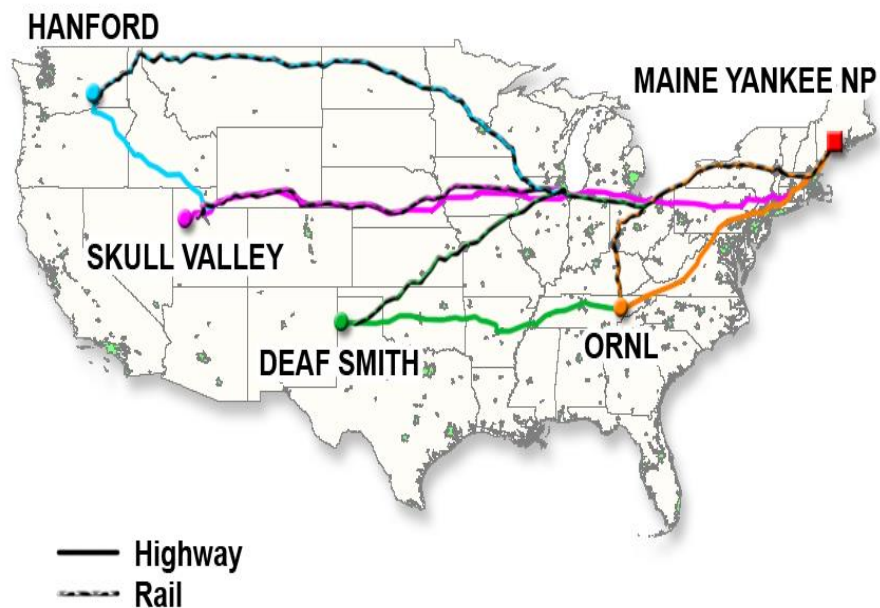

Figure 3. Highway and rail routes from Maine Yankee Nuclear Plant site. (ORNL is the Oak Ridge National Laboratory.)

## Kewaunee NP Routes

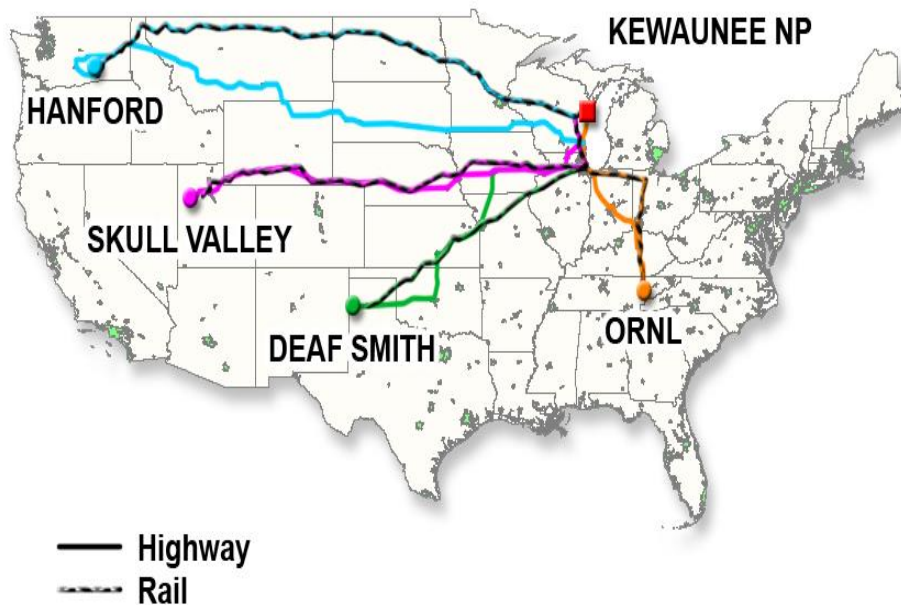

Figure 4. Highway and rail routes from Kewaunee Nuclear Plant

# Indian Point NP Routes



Figure 5. Highway and rail routes from Indian Point Nuclear Plant

# Idaho National Laboratory Routes

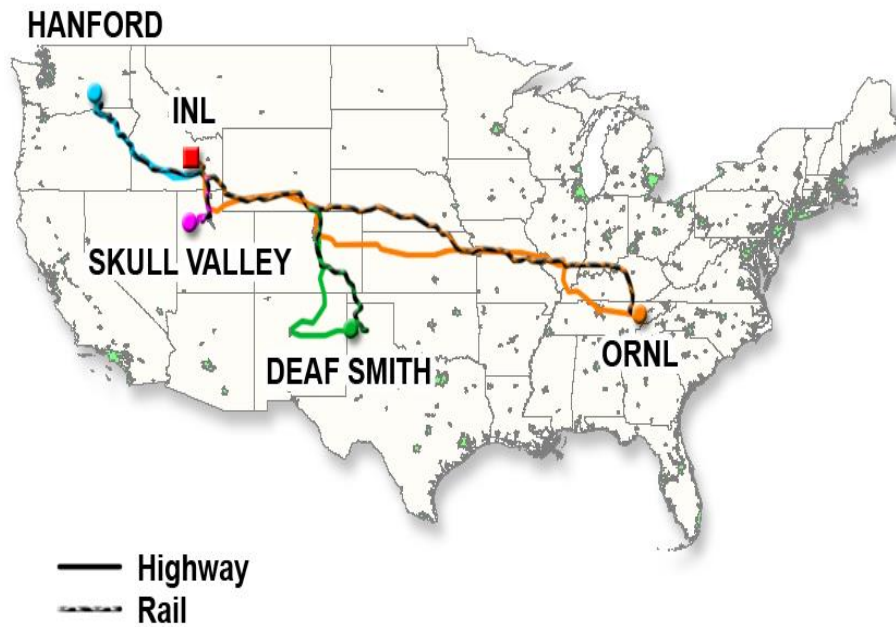

Figure 6. Highway and rail routes from Idaho National Laboratory

RADTRAN calculated the collective doses (person-Sv) to residents along the route segments for one spent fuel shipment using route segment lengths and population densities.

These routes represent a variety of route lengths and populations (Table 4). The routes include the eastern United States, western United States, and cross-country routes. They vary in length and include a variety of urban areas. Two of the three nuclear plants chosen as origin sites (Kewaunee, WI, and Maine Yankee, ME) and two of the destination sites (Hanford, WA, and Skull Valley, UT) are origins and destinations used in Sprung et al. (2000). Indian Point Nuclear Plant, NY, involves a different set of cross-country and east coast routes than Maine Yankee. It also is an operating nuclear plant whereas Maine Yankee has been decommissioned and is now a surface storage facility. The destination sites include two proposed repository sites (Deaf Smith County, TX, and Hanford, WA) (DOE, 1986), the site of the proposed private fuel storage facility (Skull Valley, UT), and ORNL. These routes were not intended to provide a “worst case” result, but were chosen to provide representative results over a broad range of conditions and large segments of the country.

**Table 4. Specific Routes Modeled**

Table note: Urban kilometers are included in total kilometers

Origin	Destination	Population within 800 m (1/2 mile)		Total Kilometers		Urban Kilometers	
		Rail	Truck	Rail	Truck	Rail	Truck
Maine Yankee Site, ME	Hanford, WA	1,647,190	1,129,685	5,084	5,013	355	116
	Deaf Smith County, TX	1,321,024	1,427,973	3,362	3,596	211	165
	Skull Valley, UT	1,451,325	1,068,032	4,068	4,174	207	115
	Oak Ridge, TN	1,146,478	1,137,834	2,125	1,748	161	135
Kewaunee NP, WI	Hanford, WA	476,914	423,163	3,028	3,453	60	52
	Deaf Smith County, TX	677,072	494,920	1,882	2,146	110	60
	Skull Valley, UT	806,115	505,226	2,755	2,620	126	58
	Oak Ridge, TN	779,613	646,034	1,395	1,273	126	92
Indian Point NP, NY	Hanford, WA	961,026	869,763	4,781	4,515	229	97
	Deaf Smith County, TX	1,027,974	968,282	3,088	3,074	204	109
	Skull Valley, UT	1,517,758	808,107	3,977	3,672	229	97
	Oak Ridge, TN	1,146,245	561,723	1,264	1,254	207	60
Idaho National Lab, ID	Hanford, WA	164,399	132,662	1,062	959	20	15
	Deaf Smith County, TX	298,590	384,912	1,913	2,291	40	52
	Skull Valley, UT	169,707	132,939	455	466	26	19
	Oak Ridge, TN	593,680	569,240	3,306	3,287	75	63

Doses along the routes modeled are shown in Tables 5 and 6. Both truck and rail versions of each route are analyzed.

Collective dose is best used in making comparisons (e.g., in comparing the risks of routine transportation along different routes, by different modes (truck or rail), or in different casks). Several comparisons can be made from the results shown in Tables 5 and 6.



- Suburban residents sustain the largest dose for all routes and shipment modes. The urban dose is less than the suburban dose because urban residences are modeled as 83 percent shielded, while suburban residences are modeled as 13 percent shielded.
- Urban residents sustain a larger dose from a single rail shipment than a truck shipment on the same route even though urban population densities are similar and the external dose rates from the cask are nearly the same. As shown in Table 4, most (though not all) rail routes have more urban miles than the analogous truck route. Train tracks go from city center to city center whereas trucks carrying spent fuel must use interstates and bypasses. In several cases shown in Table 4, the rail route had twice as many urban miles as the corresponding truck route. Also, train speeds in urban areas are only one-fourth of truck speeds.
- Overall, collective doses are larger for a single shipment on rail routes than truck routes because rail routes are often longer, especially in the western United States, where there is rarely a choice of railroads. Moreover, train speeds are lower than truck speeds, especially in urban areas. Because rail casks hold about six times as much spent fuel as the truck cask, moving a given amount of spent fuel would take six truck shipments for each rail shipment.

**Table 5. Collective Doses to Residents near the Route (Person-Sv) per Shipment for Rail Transportation**

FROM/TO	Rail-Lead				Rail-Steel			
	Rural	Suburban	Urban	Total	Rural	Suburban	Urban	Total
<b>MAINE YANKEE</b>								
ORNL	1.5x10 <sup>-5</sup>	1.8x10 <sup>-4</sup>	9.0x10 <sup>-6</sup>	2.1x10 <sup>-4</sup>	1.2x10 <sup>-5</sup>	1.4x10 <sup>-4</sup>	6.8x10 <sup>-6</sup>	1.6x10 <sup>-4</sup>
DEAF SMITH	1.9x10 <sup>-5</sup>	2.2x10 <sup>-4</sup>	1.1x10 <sup>-5</sup>	2.5x10 <sup>-4</sup>	1.4x10 <sup>-5</sup>	1.7x10 <sup>-4</sup>	8.7x10 <sup>-6</sup>	1.9x10 <sup>-4</sup>
HANFORD	2.4x10 <sup>-5</sup>	2.6x10 <sup>-4</sup>	1.3x10 <sup>-5</sup>	2.9x10 <sup>-4</sup>	1.8x10 <sup>-5</sup>	2.0x10 <sup>-4</sup>	9.9x10 <sup>-6</sup>	2.3x10 <sup>-4</sup>
SKULL VALLEY	2.6x10 <sup>-5</sup>	2.7x10 <sup>-4</sup>	1.0x10 <sup>-5</sup>	2.9x10 <sup>-4</sup>	2.0x10 <sup>-5</sup>	2.0x10 <sup>-4</sup>	7.6x10 <sup>-6</sup>	2.2x10 <sup>-4</sup>
<b>KEWAUNEE</b>								
ORNL	1.0x10 <sup>-5</sup>	1.1x10 <sup>-4</sup>	6.7x10 <sup>-6</sup>	1.3x10 <sup>-4</sup>	7.9x10 <sup>-6</sup>	8.3x10 <sup>-5</sup>	5.1x10 <sup>-6</sup>	9.6x10 <sup>-5</sup>
DEAF SMITH	8.2x10 <sup>-6</sup>	9.5x10 <sup>-5</sup>	5.8x10 <sup>-6</sup>	1.1x10 <sup>-4</sup>	6.3x10 <sup>-6</sup>	7.2x10 <sup>-5</sup>	4.4x10 <sup>-6</sup>	8.3x10 <sup>-5</sup>
HANFORD	1.2x10 <sup>-5</sup>	9.3x10 <sup>-5</sup>	3.0x10 <sup>-6</sup>	1.1x10 <sup>-4</sup>	9.3x10 <sup>-6</sup>	7.1x10 <sup>-5</sup>	2.3x10 <sup>-6</sup>	8.3x10 <sup>-5</sup>
SKULL VALLEY	1.4x10 <sup>-5</sup>	1.2x10 <sup>-4</sup>	6.6x10 <sup>-6</sup>	1.4x10 <sup>-4</sup>	1.1x10 <sup>-5</sup>	9.0x10 <sup>-5</sup>	5.0x10 <sup>-6</sup>	1.1x10 <sup>-4</sup>
<b>INDIAN POINT</b>								
ORNL	7.5x10 <sup>-6</sup>	1.4x10 <sup>-4</sup>	1.4x10 <sup>-5</sup>	1.6x10 <sup>-4</sup>	5.7x10 <sup>-6</sup>	1.1x10 <sup>-4</sup>	1.1x10 <sup>-5</sup>	1.2x10 <sup>-4</sup>
DEAF SMITH	1.7x10 <sup>-5</sup>	1.8x10 <sup>-4</sup>	1.2x10 <sup>-5</sup>	2.0x10 <sup>-4</sup>	1.3x10 <sup>-5</sup>	1.3x10 <sup>-4</sup>	8.9x10 <sup>-6</sup>	1.5x10 <sup>-4</sup>
HANFORD	2.2x10 <sup>-5</sup>	2.1x10 <sup>-4</sup>	1.3x10 <sup>-5</sup>	2.5x10 <sup>-4</sup>	1.7x10 <sup>-5</sup>	1.6x10 <sup>-4</sup>	9.9x10 <sup>-6</sup>	1.9x10 <sup>-4</sup>
SKULL VALLEY	2.3x10 <sup>-5</sup>	2.0x10 <sup>-4</sup>	1.3x10 <sup>-5</sup>	2.4x10 <sup>-4</sup>	1.7x10 <sup>-5</sup>	1.5x10 <sup>-4</sup>	1.0x10 <sup>-5</sup>	1.8x10 <sup>-4</sup>
<b>IDAHO NATIONAL LAB</b>								
ORNL	1.8x10 <sup>-5</sup>	1.1x10 <sup>-4</sup>	3.7x10 <sup>-6</sup>	1.3x10 <sup>-4</sup>	1.4x10 <sup>-5</sup>	8.6x10 <sup>-5</sup>	2.8x10 <sup>-6</sup>	1.0x10 <sup>-4</sup>
DEAF SMITH	6.6x10 <sup>-6</sup>	5.8x10 <sup>-5</sup>	2.2x10 <sup>-6</sup>	6.7x10 <sup>-5</sup>	5.0x10 <sup>-6</sup>	4.5x10 <sup>-5</sup>	1.7x10 <sup>-6</sup>	5.2x10 <sup>-5</sup>
HANFORD	5.3x10 <sup>-6</sup>	3.0x10 <sup>-5</sup>	1.1x10 <sup>-6</sup>	3.6x10 <sup>-5</sup>	4.0x10 <sup>-6</sup>	2.3x10 <sup>-5</sup>	8.2x10 <sup>-7</sup>	2.8x10 <sup>-5</sup>
SKULL VALLEY	3.0x10 <sup>-6</sup>	2.5x10 <sup>-5</sup>	1.5x10 <sup>-6</sup>	3.0x10 <sup>-5</sup>	2.3x10 <sup>-6</sup>	1.9x10 <sup>-5</sup>	1.1x10 <sup>-6</sup>	2.2x10 <sup>-5</sup>

**Table 6. Collective Doses to Residents near the Route (person-Sv) for Truck Transportation per Shipment**

FROM	TO	Truck-DU				
		Rural	Suburban	Urban	Urban Rush Hour <sup>a</sup>	Total
MAINE YANKEE	ORNL	5.0x10 <sup>-6</sup>	8.9x10 <sup>-5</sup>	2.0x10 <sup>-6</sup>	4.5x10 <sup>-7</sup>	9.6x10 <sup>-5</sup>
	DEAF SMITH	1.0x10 <sup>-5</sup>	1.2x10 <sup>-4</sup>	2.1x10 <sup>-6</sup>	4.8x10 <sup>-7</sup>	1.4x10 <sup>-4</sup>
	HANFORD	1.4x10 <sup>-5</sup>	1.0x10 <sup>-4</sup>	1.5x10 <sup>-6</sup>	3.2x10 <sup>-7</sup>	1.2x10 <sup>-4</sup>
	SKULL VALLEY	1.1x10 <sup>-5</sup>	9.5x10 <sup>-5</sup>	1.5x10 <sup>-6</sup>	3.3x10 <sup>-7</sup>	1.1x10 <sup>-4</sup>
KEWAUNEE	ORNL	4.1x10 <sup>-6</sup>	4.6x10 <sup>-5</sup>	1.1x10 <sup>-6</sup>	2.5x10 <sup>-7</sup>	5.2x10 <sup>-5</sup>
	DEAF SMITH	6.6x10 <sup>-6</sup>	3.9x10 <sup>-5</sup>	7.6x10 <sup>-7</sup>	1.7x10 <sup>-7</sup>	4.7x10 <sup>-5</sup>
	HANFORD	9.1x10 <sup>-6</sup>	4.1x10 <sup>-5</sup>	7.0x10 <sup>-7</sup>	1.5x10 <sup>-7</sup>	5.1x10 <sup>-5</sup>
	SKULL VALLEY	7.3x10 <sup>-6</sup>	3.1x10 <sup>-5</sup>	6.7x10 <sup>-7</sup>	1.5x10 <sup>-7</sup>	3.9x10 <sup>-5</sup>
INDIAN POINT	ORNL	4.1x10 <sup>-6</sup>	6.4x10 <sup>-5</sup>	1.6x10 <sup>-7</sup>	1.6x10 <sup>-7</sup>	6.9x10 <sup>-5</sup>
	DEAF SMITH	1.3x10 <sup>-5</sup>	1.3x10 <sup>-4</sup>	6.9x10 <sup>-7</sup>	3.1x10 <sup>-7</sup>	1.4x10 <sup>-4</sup>
	HANFORD	1.3x10 <sup>-5</sup>	7.6x10 <sup>-5</sup>	2.6x10 <sup>-7</sup>	2.6x10 <sup>-7</sup>	8.9x10 <sup>-5</sup>
	SKULL VALLEY	1.0x10 <sup>-5</sup>	6.6x10 <sup>-5</sup>	2.7x10 <sup>-7</sup>	2.7x10 <sup>-7</sup>	7.7x10 <sup>-5</sup>
IDAHO NATIONAL LAB	ORNL	8.8x10 <sup>-6</sup>	5.3x10 <sup>-5</sup>	7.7x10 <sup>-7</sup>	1.7x10 <sup>-7</sup>	6.3x10 <sup>-5</sup>
	DEAF SMITH	4.6x10 <sup>-6</sup>	3.0x10 <sup>-5</sup>	6.9x10 <sup>-7</sup>	1.5x10 <sup>-7</sup>	3.7x10 <sup>-5</sup>
	HANFORD	5.5x10 <sup>-6</sup>	8.8x10 <sup>-6</sup>	1.1x10 <sup>-7</sup>	4.2x10 <sup>-8</sup>	1.4x10 <sup>-5</sup>
	SKULL VALLEY	1.2x10 <sup>-6</sup>	1.0x10 <sup>-5</sup>	2.7x10 <sup>-7</sup>	5.9x10 <sup>-8</sup>	1.2x10 <sup>-5</sup>

<sup>a</sup> During rush hour RADTRAN halves the truck speed and doubles the vehicle density to take into account traffic jams and gridlock..

- The collective doses shown in Tables 5 and 6 are all very small. However, they are not the only doses people along the route receive. Background radiation is 0.0036 Sv (360 mrem) per year in the United States, or 4.1x10<sup>-7</sup> Sv/hour (0.041 mrem/hr). The contribution of a single shipment to the population's collective dose is illustrated in the following example of the Maine Yankee to ORNL truck route:
  - From Table 6 the total collective dose to residents for this route is 9.6x10<sup>-5</sup> person-Sv (9.6 person-mrem).
  - From Table 4, there are 1,137,834 people within 800 meters (1/2 mile) of the route.
  - Background is 4.1x10<sup>-7</sup> Sv/hour (0.041 mrem/hr), which everyone is exposed to all the time, whether a shipment occurs or not.
  - A truck traveling at an average of 108 km per hour (67 mph) travels the 1,748 km (1086 miles) in 16 hours.

- During those 16 hours, the 1,137,834 people will have received a collective background dose of 7.56 person-Sv, (756 person-rem) about 80,000 times the collective dose from the shipment.
- To illustrate, the total collective dose during a shipment to these 1,137,834 people is not  $9.6 \times 10^{-5}$  person-Sv ( $9.6 \times 10^{-3}$  person-rem), but 7.560096 person-Sv (756.0096 person-rem).
- The NRC recommends that collective dose only be used for comparative purposes (NRC, 2008).
- The appropriate comparison between the collective dose from this shipment of spent fuel is not a comparison between  $9.6 \times 10^{-5}$  person-Sv ( $9.6 \times 10^{-3}$  person-rem) from the shipment and zero dose if there is no shipment, but between 7.560096 person-Sv (756.0096 person-rem) if there is a shipment and 7.560000 person-Sv (756.0000 person-rem) if there is no shipment.

### *Doses to Members of the Public Occupying Vehicles that Share the Route*

#### Rail

Most U.S. rail is either double track or equipped with “passing tracks” that let one train pass another. When a train passes the train carrying the spent fuel cask, occupants of the passing train will receive some external radiation. Most trains in the United States carry freight, and the only occupants of the passing train are crew members. Only about one railcar in 60 has an occupant.

The dose to occupants of other trains in this situation depends on train speed and the external dose rate from the spent fuel casks. Table 7 shows the collective dose to public passengers of trains sharing the route, assuming for calculation purposes that train occupants are represented by one person in each passing railcar in rural and suburban areas, and five people in urban areas.<sup>§§</sup> The rural and suburban collective doses probably are unrealistically high, since most freight rail going through rural and many suburban areas never encounters a passenger train. Data were not available to account for the occupancy of actual passenger trains, including commuter rail, that share rail routes with freight trains.

---

<sup>§§</sup> The five persons per railcar in urban areas are assumed to include occupants of passenger trains. Passenger trains carry more than five per car, but the majority of railcars even in urban areas carry freight only. This estimate is consistent with estimates made in past studies.

**Table 7. Collective Doses (Person-Sv) per Shipment to Occupants of Trains Sharing Rail Routes (1 Sv=10<sup>5</sup> mrem)**

SHIPMENT ORIGIN/ DESTINATION	Rail-Lead Cask				Rail-Steel Cask			
	Rural	Suburban	Urban	Total	Rural	Suburban	Urban	Total
<b>MAINE YANKEE</b>								
ORNL	2.0x10 <sup>-5</sup>	1.2x10 <sup>-5</sup>	7.5x10 <sup>-6</sup>	4.0x10 <sup>-5</sup>	1.5x10 <sup>-5</sup>	9.3x10 <sup>-6</sup>	5.6x10 <sup>-6</sup>	3.0x10 <sup>-5</sup>
DEAF SMITH	3.8x10 <sup>-5</sup>	1.3x10 <sup>-5</sup>	9.7x10 <sup>-6</sup>	6.1x10 <sup>-5</sup>	2.9x10 <sup>-5</sup>	1.0x10 <sup>-5</sup>	7.4x10 <sup>-6</sup>	4.6x10 <sup>-5</sup>
HANFORD	6.2x10 <sup>-5</sup>	1.7x10 <sup>-5</sup>	1.6x10 <sup>-5</sup>	9.0x10 <sup>-5</sup>	4.7x10 <sup>-5</sup>	1.3x10 <sup>-5</sup>	1.2x10 <sup>-5</sup>	6.8x10 <sup>-5</sup>
SKULL VALLEY	4.8x10 <sup>-5</sup>	1.6x10 <sup>-5</sup>	9.6x10 <sup>-6</sup>	7.4x10 <sup>-5</sup>	3.6x10 <sup>-5</sup>	1.2x10 <sup>-5</sup>	7.3x10 <sup>-6</sup>	5.5x10 <sup>-5</sup>
<b>KEWAUNEE</b>								
ORNL	1.4x10 <sup>-5</sup>	7.0x10 <sup>-6</sup>	5.8x10 <sup>-6</sup>	2.7x10 <sup>-5</sup>	1.0x10 <sup>-5</sup>	5.3x10 <sup>-6</sup>	4.4x10 <sup>-6</sup>	2.0x10 <sup>-5</sup>
DEAF SMITH	2.4x10 <sup>-5</sup>	5.2x10 <sup>-6</sup>	5.1x10 <sup>-6</sup>	3.4x10 <sup>-5</sup>	1.8x10 <sup>-5</sup>	4.0x10 <sup>-6</sup>	3.9x10 <sup>-6</sup>	2.6x10 <sup>-5</sup>
HANFORD	4.2x10 <sup>-5</sup>	6.7x10 <sup>-6</sup>	2.8x10 <sup>-6</sup>	5.2x10 <sup>-5</sup>	3.2x10 <sup>-5</sup>	5.1x10 <sup>-6</sup>	2.1x10 <sup>-6</sup>	3.9x10 <sup>-5</sup>
SKULL VALLEY	3.5x10 <sup>-5</sup>	7.8x10 <sup>-6</sup>	5.8x10 <sup>-6</sup>	4.9x10 <sup>-5</sup>	2.7x10 <sup>-5</sup>	5.9x10 <sup>-6</sup>	4.4x10 <sup>-6</sup>	3.7x10 <sup>-5</sup>
<b>INDIAN POINT</b>								
ORNL	9.2x10 <sup>-6</sup>	8.1x10 <sup>-6</sup>	9.6x10 <sup>-6</sup>	2.7x10 <sup>-5</sup>	7.0x10 <sup>-6</sup>	6.1x10 <sup>-6</sup>	7.2x10 <sup>-6</sup>	2.0x10 <sup>-5</sup>
DEAF SMITH	3.6x10 <sup>-5</sup>	1.1x10 <sup>-5</sup>	9.4x10 <sup>-6</sup>	5.6x10 <sup>-5</sup>	2.8x10 <sup>-5</sup>	8.2x10 <sup>-6</sup>	7.1x10 <sup>-6</sup>	4.3x10 <sup>-5</sup>
HANFORD	6.0x10 <sup>-5</sup>	1.4x10 <sup>-5</sup>	1.1x10 <sup>-5</sup>	8.5x10 <sup>-5</sup>	4.6x10 <sup>-5</sup>	1.1x10 <sup>-5</sup>	8.0x10 <sup>-6</sup>	6.5x10 <sup>-5</sup>
SKULL VALLEY	4.8x10 <sup>-5</sup>	1.3x10 <sup>-5</sup>	1.1x10 <sup>-5</sup>	6.5x10 <sup>-5</sup>	3.6x10 <sup>-5</sup>	1.0x10 <sup>-5</sup>	8.0x10 <sup>-6</sup>	4.9x10 <sup>-5</sup>
<b>INL</b>								
ORNL	4.6x10 <sup>-5</sup>	7.1x10 <sup>-6</sup>	3.4x10 <sup>-6</sup>	5.7x10 <sup>-5</sup>	3.5x10 <sup>-5</sup>	5.4x10 <sup>-6</sup>	2.6x10 <sup>-6</sup>	4.3x10 <sup>-5</sup>
DEAF SMITH	2.7x10 <sup>-5</sup>	3.2x10 <sup>-6</sup>	1.9x10 <sup>-6</sup>	3.2x10 <sup>-5</sup>	2.1x10 <sup>-5</sup>	2.5x10 <sup>-6</sup>	1.4x10 <sup>-6</sup>	2.5x10 <sup>-5</sup>
HANFORD	1.5x10 <sup>-5</sup>	1.7x10 <sup>-6</sup>	9.3x10 <sup>-7</sup>	1.8x10 <sup>-5</sup>	1.2x10 <sup>-5</sup>	1.3x10 <sup>-6</sup>	7.0x10 <sup>-7</sup>	1.4x10 <sup>-5</sup>
SKULL VALLEY	5.5x10 <sup>-6</sup>	1.5x10 <sup>-6</sup>	1.2x10 <sup>-6</sup>	8.2x10 <sup>-6</sup>	4.2x10 <sup>-6</sup>	1.1x10 <sup>-6</sup>	9.0x10 <sup>-7</sup>	6.2x10 <sup>-6</sup>

**Truck**

Unlike trains, trucks carrying spent fuel share the primary highway system with many cars, light trucks, and other vehicles. The occupants of any car or truck that passes the spent fuel cask in either direction will receive a small radiation dose. This dose is modeled in RADTRAN as shown in Figure 7. RADTRAN assumes there is always a vehicle in the adjacent lane.

The radiation dose to occupants of other vehicles depends on the exposure distance and time, the number of other vehicles on the road, and the number of people in the other vehicles. Occupants of the vehicles that share the route are closer to the cask than residents or others beside the route. Occupants of vehicles moving in the opposite direction from the cask are exposed to radiation from the cask for considerably less time because the vehicles involved are moving past each other. The exposure time for vehicles traveling in the same direction as the cask is assumed to be the time needed to travel the link at the average speed (Neuhauser et al., 2000). It is assumed that there is always a vehicle in the adjacent lane at the position of the cask and a vehicle in the same lane at the MIN distance from the cask. The number of other vehicles that share truck routes is

very large; the average number of vehicles per hour on U.S. interstate and primary highways in 2004<sup>\*\*\*</sup> (Weiner et al., 2009, Appendix D) were:

- 1,119 on rural segments, about 2.5 times the 1977 vehicle density
- 2,464 on suburban segments, almost four times the 1977 vehicle density
- 5,384 on urban segments, about twice the 1977 vehicle density

Each vehicle was assumed to have an average of 1.5 occupants since most cars and light trucks traveling on freeways have one or two occupants. State highway departments provide traffic count data but do not provide vehicle occupancy data. If two occupants are assumed, the collective doses are one-third larger.

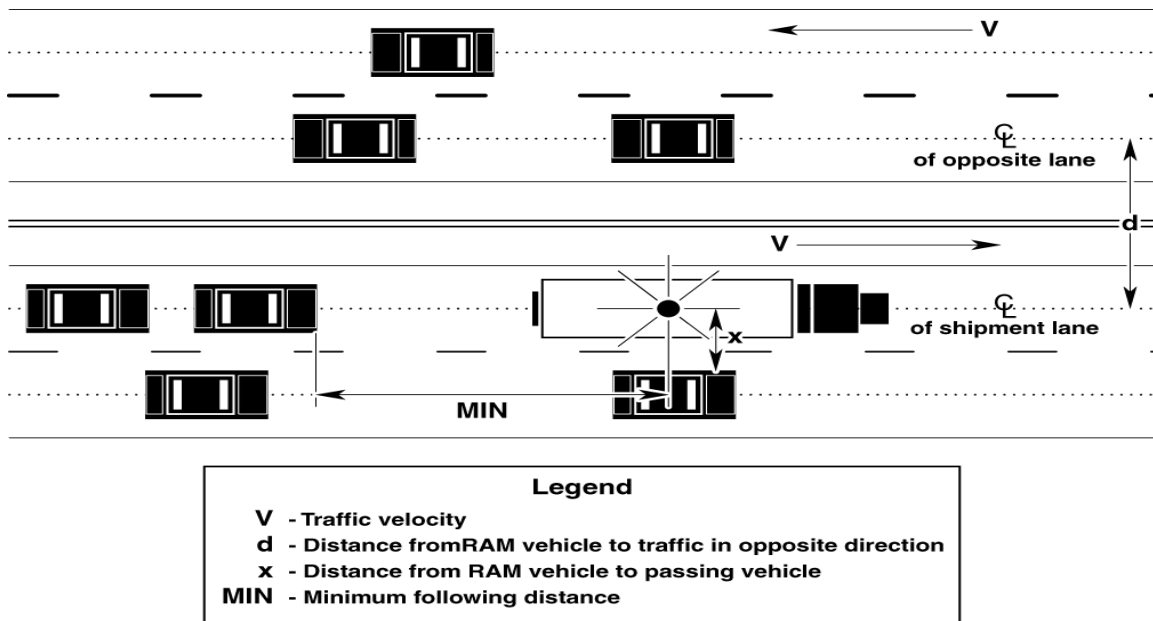

**Figure 7. Diagram used in RADTRAN for calculating radiation doses to occupants of other vehicles (from Neuhauser et al., 2000)**

Detailed discussion and state-by-state results are presented in NRC (2012) Appendix II. The collective doses for truck traffic are shown in Table 8.

<sup>\*\*\*</sup> 2004 is the most recent year for which data have been validated.

**Table 8. Collective Doses (Person-Sv) per Shipment to Occupants of Vehicles Sharing Truck Routes**

FROM	TO	Truck-DU				
		Rural	Suburban	Urban	Urban Rush Hour <sup>a</sup>	Total <sup>b</sup>
MAINE YANKEE	ORNL	1.3x10 <sup>-4</sup>	2.4x10 <sup>-4</sup>	5.2x10 <sup>-5</sup>	4.8x10 <sup>-5</sup>	4.6x10 <sup>-4</sup>
	DEAF SMITH	2.8x10 <sup>-4</sup>	3.3x10 <sup>-4</sup>	6.9x10 <sup>-5</sup>	6.4x10 <sup>-5</sup>	7.3x10 <sup>-4</sup>
	HANFORD	4.5x10 <sup>-4</sup>	3.0x10 <sup>-4</sup>	4.3x10 <sup>-5</sup>	4.0x10 <sup>-5</sup>	8.3x10 <sup>-4</sup>
	SKULL VALLEY	3.7x10 <sup>-4</sup>	2.5x10 <sup>-4</sup>	4.4x10 <sup>-5</sup>	4.5x10 <sup>-5</sup>	7.0x10 <sup>-4</sup>
KEWAUNEE	ORNL	9.6x10 <sup>-5</sup>	1.4x10 <sup>-4</sup>	4.8x10 <sup>-5</sup>	4.4x10 <sup>-5</sup>	3.3x10 <sup>-4</sup>
	DEAF SMITH	1.8x10 <sup>-4</sup>	8.9x10 <sup>-5</sup>	2.2x10 <sup>-5</sup>	2.0x10 <sup>-5</sup>	3.1x10 <sup>-4</sup>
	HANFORD	3.4x10 <sup>-4</sup>	1.4x10 <sup>-4</sup>	3.3x10 <sup>-5</sup>	3.0x10 <sup>-5</sup>	5.4x10 <sup>-4</sup>
	SKULL VALLEY	2.4x10 <sup>-4</sup>	8.6x10 <sup>-5</sup>	2.5x10 <sup>-5</sup>	2.3x10 <sup>-5</sup>	3.8x10 <sup>-4</sup>
INDIAN POINT	ORNL	1.8x10 <sup>-4</sup>	2.1x10 <sup>-4</sup>	3.3x10 <sup>-5</sup>	3.0x10 <sup>-5</sup>	4.6x10 <sup>-4</sup>
	DEAF SMITH	2.8x10 <sup>-4</sup>	3.1x10 <sup>-4</sup>	5.6x10 <sup>-5</sup>	5.2x10 <sup>-5</sup>	6.9x10 <sup>-4</sup>
	HANFORD	4.2x10 <sup>-4</sup>	2.2x10 <sup>-4</sup>	4.8x10 <sup>-5</sup>	4.4x10 <sup>-5</sup>	7.2x10 <sup>-4</sup>
	SKULL VALLEY	3.6x10 <sup>-4</sup>	2.2x10 <sup>-4</sup>	4.5x10 <sup>-5</sup>	4.1x10 <sup>-5</sup>	6.6x10 <sup>-4</sup>
IDAHO NATIONAL LAB	ORNL	3.0x10 <sup>-4</sup>	1.5x10 <sup>-4</sup>	2.4x10 <sup>-5</sup>	2.2x10 <sup>-5</sup>	5.0x10 <sup>-4</sup>
	DEAF SMITH	2.2x10 <sup>-4</sup>	7.3x10 <sup>-5</sup>	2.7x10 <sup>-5</sup>	2.5x10 <sup>-5</sup>	3.4x10 <sup>-4</sup>
	HANFORD	1.0x10 <sup>-4</sup>	8.5x10 <sup>-5</sup>	9.5x10 <sup>-6</sup>	8.7x10 <sup>-6</sup>	2.0x10 <sup>-4</sup>
	SKULL VALLEY	3.7x10 <sup>-5</sup>	3.2x10 <sup>-5</sup>	8.5x10 <sup>-6</sup>	7.8x10 <sup>-6</sup>	8.5x10 <sup>-5</sup>

<sup>a</sup> During rush hour the truck speed is halved and the vehicle density is doubled, for details see Section 5.3 in NRC (2012) Appendix II.

<sup>b</sup> Total includes the sum of Rural, Suburban, Urban, and Urban Rush Hour.

### *Doses at Truck and Train Stops*

Trucks and trains occasionally stop on long trips. Common carrier freight trains stop to exchange freight cars, change crews, and, when necessary, change railroads. The rail stops at the origin and destination of a trip are called “classification stops” and are approximately 27 to 30 hours long (Wooden, 1986). Spent fuel casks may be carried on both dedicated trains and regular freight trains; however, in practice, previous spent fuel shipments have been carried on dedicated trains. A dedicated train is a train that carries a single cargo from origin to destination. Coal unit trains are an example of dedicated trains. The analyses conducted in this study assume that the casks are transported on dedicated trains, which eliminates the need for intermediate classification stops.

When a train is stopped, the dose to anyone nearby depends on the distance between that person and the cask and the time that the individual is exposed. People exposed at a rail stop include those listed below.

- railyard workers (including inspectors)
- train crew (passenger trains do not typically enter railyards)
- residents who live near the railyard

The semi-tractor trucks that carry Truck-DU casks each have two 300-liter (80-gallon) fuel tanks. They generally stop to refuel when half of the fuel is gone, approximately every 845 km (525 miles) (DOE, 2002). Trucks carrying spent fuel also are stopped at the origin and destination of each trip. Mandatory rest and crew changes are combined with refueling stops whenever possible.

The people likely to be exposed at a refueling truck stop are listed below.

- the truck crew of two; usually one crew member at a time fills the tanks
- other people using the truck stop (since these trucks stop at public truck stops)
- residents of areas near the stop

Some states inspect spent fuel cask shipments when the trucks enter the state. Inspection stations may be combined with truck weigh stations; therefore, inspectors of both the truck carrying the spent fuel and the trucks carrying other goods can be exposed in addition to crew from other trucks. When the vehicle is stopped, receptor doses depend only on distance from the source and exposure time, so that any situation in which the cask and the receptor stay at a fixed distance from each other can be modeled as a stop. These exposure situations include inspections, vehicle escorts, vehicle crew when the vehicle is in transit, and occupants of other vehicles near the stopped vehicle. Any of these situations can be modeled in RADTRAN. NRC (2012) Appendix II provides details on the calculations performed for situations in this analysis.

Figure 8 is a diagram of the model used to calculate doses at stops – a spent fuel truck refueling stop in this example. The inner circle defines the area occupied by people who share the stop with the spent fuel truck, who are between the truck and the building, and who are not shielded from the truck's external radiation. People in buildings at the stop are considered to be shielded.

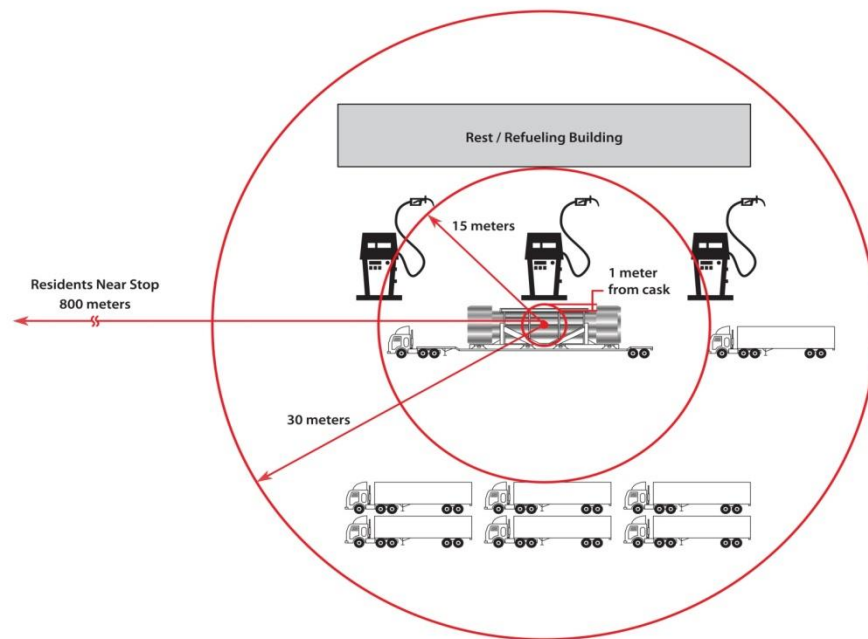

**Figure 8. Diagram of truck stop model (not to scale).**

Table 9 lists the input data used to calculate doses at truck and train stops.

**Table 9. Input Data for Calculating Doses at Truck and Train Stops**

Data	Interstate Highway	Freight Rail
Minimum distance from nearby residents, m (ft)	30 (100)	200 (660)
Maximum distance from nearby residents, m (miles)	800 (1/2)	800 (1/2)
Stop time for rail classification (hours)	NA	27
Stop time in transit for railroad change (hours)	NA	<<1 to 4
Stop time at truck stops (hours)	0.83	NA
Minimum distance to people sharing the stop, m (ft)	1 (3.3) <sup>a</sup>	NA
Maximum distance to people sharing the stop, m (ft)	15 (50) <sup>a</sup>	NA

<sup>a</sup>From Griego et al., 1996

#### Rail

Trains are stopped for classification for 27 hours at the beginning and end of a trip. The collective dose from the radioactive cargo to the railyard workers at these classification stops is incorporated into RADTRAN and, for the two rail casks studied, is:

- $1.46 \times 10^{-5}$  person-Sv (1.46 person-mrem) for the Rail-Lead cask
- $1.09 \times 10^{-5}$  person-Sv (1.09 person-mrem) for the Rail-Steel cask

The average dose (calculated by dividing the collective dose by the number of exposed people) to an individual living between 200 and 800 meters from a classification yard is:

- $3.5 \times 10^{-7}$  Sv (0.035 mrem) from the Rail-Lead cask
- $2.7 \times 10^{-7}$  Sv (0.027 mrem) from the Rail-Steel cask

Table 10 shows the doses to yard workers and residents near the stops for the Maine Yankee-to-Hanford rail route, calculated using the input data from Table 9. The doses for all 16 rail routes were calculated in a similar fashion and are presented in Table 11. The difference in collective dose to residents near stops from route-to-route is primarily due to the different population densities at the classification stops, which may be either in rural or suburban areas.



**Table 10. Collective Doses at Rail Stops on the Maine Yankee-to-Hanford Route (Person-Sv)**

Stop	Route type (R, S, U) and State	Time (hours)	Railyard Worker		Residents Near Stop	
			Rail-Lead	Rail-Steel	Rail-Lead	Rail-Steel
Classification, origin	S, ME	27	$1.5 \times 10^{-5}$	$1.1 \times 10^{-5}$	$2.3 \times 10^{-5}$	$1.8 \times 10^{-5}$
In route 1	S, ME	4.0	$2.2 \times 10^{-6}$	$1.6 \times 10^{-6}$	$3.4 \times 10^{-6}$	$2.6 \times 10^{-6}$
In route 2	R, NY	4.0	$2.2 \times 10^{-6}$	$1.6 \times 10^{-6}$	$9.2 \times 10^{-7}$	$6.9 \times 10^{-7}$
In route 3	S, IL	2.0	$1.1 \times 10^{-6}$	$8.1 \times 10^{-7}$	$1.2 \times 10^{-5}$	$9.4 \times 10^{-6}$
Classification, destination	S, WA	27	$1.5 \times 10^{-5}$	$1.1 \times 10^{-5}$	$1.9 \times 10^{-5}$	$1.4 \times 10^{-5}$

**Table 11. Collective Dose to Residents near Stops and Workers at Stops and Onboard the Train (Person-Sv)**

ORIGIN	DESTINATION	RESIDENTS NEAR STOPS		RAILYARD WORKERS, CREW, AND ESCORTS	
		RAIL LEAD	RAIL STEEL	RAIL LEAD	RAIL STEEL
MAINE YANKEE	ORNL	$1.1 \times 10^{-4}$	$8.5 \times 10^{-5}$	$3.4 \times 10^{-4}$	$2.3 \times 10^{-4}$
	DEAF SMITH	$5.3 \times 10^{-5}$	$5.0 \times 10^{-5}$	$5.1 \times 10^{-4}$	$3.7 \times 10^{-4}$
	HANFORD	$1.1 \times 10^{-4}$	$8.8 \times 10^{-5}$	$7.6 \times 10^{-4}$	$5.6 \times 10^{-4}$
	SKULL VALLEY	$5.4 \times 10^{-5}$	$4.1 \times 10^{-5}$	$6.2 \times 10^{-4}$	$4.5 \times 10^{-4}$
KEWAUNEE	ORNL	$1.1 \times 10^{-4}$	$8.3 \times 10^{-5}$	$2.3 \times 10^{-4}$	$1.5 \times 10^{-4}$
	DEAF SMITH	$6.8 \times 10^{-5}$	$5.2 \times 10^{-5}$	$3.0 \times 10^{-4}$	$2.1 \times 10^{-4}$
	HANFORD	$1.1 \times 10^{-4}$	$8.7 \times 10^{-5}$	$4.7 \times 10^{-4}$	$3.3 \times 10^{-4}$
	SKULL VALLEY	$1.2 \times 10^{-4}$	$9.1 \times 10^{-5}$	$4.3 \times 10^{-4}$	$3.0 \times 10^{-4}$
INDIAN POINT	ORNL	$1.3 \times 10^{-4}$	$1.0 \times 10^{-4}$	$2.1 \times 10^{-4}$	$1.4 \times 10^{-4}$
	DEAF SMITH	$5.9 \times 10^{-5}$	$4.5 \times 10^{-5}$	$4.8 \times 10^{-4}$	$3.4 \times 10^{-4}$
	HANFORD	$1.1 \times 10^{-4}$	$8.3 \times 10^{-5}$	$7.2 \times 10^{-4}$	$5.2 \times 10^{-4}$
	SKULL VALLEY	$5.6 \times 10^{-5}$	$4.3 \times 10^{-5}$	$6.0 \times 10^{-4}$	$4.4 \times 10^{-4}$
INL	ORNL	$9.5 \times 10^{-5}$	$7.2 \times 10^{-5}$	$5.1 \times 10^{-4}$	$3.6 \times 10^{-4}$
	DEAF SMITH	$7.7 \times 10^{-5}$	$5.8 \times 10^{-5}$	$3.1 \times 10^{-4}$	$2.1 \times 10^{-4}$
	HANFORD	$5.6 \times 10^{-5}$	$4.3 \times 10^{-5}$	$1.8 \times 10^{-4}$	$1.2 \times 10^{-4}$
	SKULL VALLEY	$3.1 \times 10^{-6}$	$2.4 \times 10^{-6}$	$9.5 \times 10^{-5}$	$5.0 \times 10^{-5}$

Truck

Table 12 shows the collective doses to residents near stops for the rural and suburban segments of the 16 truck routes studied calculated using the input data from Table 9. Urban stops were not modeled because trucks carrying spent fuel casks are unlikely to stop in urban areas, because most truck stops are not in urban areas. Truck stops in metropolitan areas are usually in sparsely populated industrial areas, and because the DOT routing rules require using urban bypass routes (49 CFR Part 356). NRC (2012) Appendix II provides a detailed discussion and example of the calculations performed to derive this table.

**Table 12. Collective Doses to Residents near Truck Stops (Person-Sv)**

Origin	Destination	Type	Persons/km <sup>2</sup> (persons/mi <sup>2</sup> )	Number of Stops	Dose
MAINE YANKEE	ORNL	Rural	19.9 (51.5)	1.14	7.4 x10 <sup>-7</sup>
		Suburban	395 (1023)	0.93	1.0 x10 <sup>-5</sup>
	Deaf Smith	Rural	18.6 (48.2)	2.47	1.5 x10 <sup>-6</sup>
		Suburban	371 (961)	1.6	1.7 x10 <sup>-5</sup>
	Hanford	Rural	15.4 (39.9)	4.33	2.2 x10 <sup>-6</sup>
		Suburban	325 (842)	1.5	1.4 x10 <sup>-5</sup>
	Skull Valley	Rural	16.9 (43.8)	3.5	1.9 x10 <sup>-6</sup>
		Suburban	333 (861)	1.3	1.2 x10 <sup>-5</sup>
KEWAUNEE	ORNL	Rural	19.8 (51.3)	0.81	5.2 x10 <sup>-7</sup>
		Suburban	361 (935)	0.59	6.0 x10 <sup>-6</sup>
	Deaf Smith	Rural	13.5 (35.0)	2.0	8.6 x10 <sup>-7</sup>
		Suburban	339 (878)	0.52	5.0 x10 <sup>-6</sup>
	Hanford	Rural	10.5 (27.2)	3.4	1.2 x10 <sup>-6</sup>
		Suburban	316 (818)	0.60	5.4 x10 <sup>-6</sup>
	Skull Valley	Rural	12.5 (32.4)	2.6	1.1 x10 <sup>-6</sup>
		Suburban	325 (840)	0.44	4.1 x10 <sup>-6</sup>
INDIAN POINT	ORNL	Rural	20.5 (53.1)	0.71	4.7 x10 <sup>-7</sup>
		Suburban	388 (1005)	0.71	7.8 x10 <sup>-6</sup>
	Deaf Smith	Rural	17.1 (44.3)	2.3	1.3 x10 <sup>-6</sup>
		Suburban	370 (958)	1.2	1.3 x10 <sup>-5</sup>
	Hanford	Rural	13.0 (33.7)	4.1	1.8 x10 <sup>-6</sup>
		Suburban	338 (875)	1.1	1.1 x10 <sup>-5</sup>
	Skull Valley	Rural	14.2 (36.8)	3.3	1.5 x10 <sup>-6</sup>
		Suburban	351 (909)	0.93	9.3 x10 <sup>-6</sup>
IDAHO NATIONAL LAB	ORNL	Rural	12.4 (32.1)	3.1	1.3 x10 <sup>-6</sup>
		Suburban	304 (787)	0.72	6.3 x10 <sup>-6</sup>
	Deaf Smith	Rural	7.8 (20.2)	2.3	5.8 x10 <sup>-7</sup>
		Suburban	339 (878)	0.35	3.4 x10 <sup>-6</sup>
	Hanford	Rural	6.5 (16.8)	0.43	9.0x10 <sup>-8</sup>
		Suburban	200 (518)	0.57	3.2 x10 <sup>-6</sup>
	Skull Valley	Rural	10.1 (26.2)	0.42	1.4 x10 <sup>-7</sup>
		Suburban	343 (888)	0.11	1.1 x10 <sup>-6</sup>

The rural and suburban population densities in Table 12 are averages for the entire route. An analogous calculation can be made for each state traversed. However, in neither case can it be determined beforehand exactly where the truck will stop to refuel. In some cases (e.g., INL to Skull Valley) the truck may not stop at all since the total distance from INL to the Skull Valley site is only 466.2 km (290 miles). The route from Indian Point to ORNL illustrates another situation. This route is 1,028 km (639 miles) long and would include one truck stop. This stop could occur in a rural or suburban area. The results shown in Table 12 are general average doses at stops.

### Doses to Workers

Radiation doses to workers are limited in accordance with the regulations in 10 CFR Part 20, which states maintaining worker exposure to ionizing radiation “as low as is reasonably achievable” (ALARA), which applies to occupational doses.

Occupational doses from routine, incident-free radioactive materials transportation include doses to truck and train crew, railyard workers, truck-stop workers, inspectors, and escorts. Workers not included are those who handle spent fuel containers in storage, load and unload casks from vehicles or during intermodal transfer, and attendants who refuel trucks. Most truck refueling stops in the United States no longer have such attendants.<sup>†††</sup>

Table 13 summarizes the occupational doses. All doses are per hour except for the truck stop worker (reported for the maximum truck stop time) and the rail classification yard workers. All doses are individual doses (Sv) except for the railyard worker collective doses.

**Table 13. Occupational Doses and Dose Rates from Routine Incident-Free Transportation**

Cask and route type	Train crew in transit: 3 people; person-Sv/km	Truck crew in transit 2 people; person-Sv/km <sup>a</sup>	Escort: Sv/hour <sup>a</sup>	Inspector: Average Sv per 8 inspections <sup>c</sup>	Truck stop worker: Sv per stop	Rail classification yard workers: person-Sv /stop
Rail-Lead rural/suburban	4.3x10 <sup>-7</sup>		5.8x10 <sup>-6</sup>			1.5x10 <sup>-5</sup>
Rail-Lead urban	7.2x10 <sup>-7</sup>		5.8x10 <sup>-6</sup>			<sup>b</sup>
Rail-Steel rural/suburban	3.3x10 <sup>-7</sup>		4.4x10 <sup>-6</sup>			1.1x10 <sup>-5</sup>
Rail-Steel urban	5.5x10 <sup>-7</sup>		4.4x10 <sup>-6</sup>			<sup>b</sup>
Truck - DU rural/suburban		3.8x10 <sup>-7</sup>	4.9x10 <sup>-9</sup>	1.5x10 <sup>-3</sup>	6.7x10 <sup>-6</sup>	
Truck - DU urban		3.6x10 <sup>-7</sup>	4.9x10 <sup>-9</sup>			

<sup>a</sup> The truck crew is shielded while in transit to sustain a maximum dose of 0.02 mSv/hour

<sup>b</sup> Even classification yards within metropolitan areas do not typically have urban population densities because of the large area the classification yard occupies.

<sup>c</sup> The average number of state boundaries crossed for all 16 routes is eight. The average dose to an inspector from each of these inspections is 1.64 x 10<sup>-4</sup> Sv (0.0164 rem).

<sup>†††</sup> The States of Oregon and New Jersey still require gas station attendants to refuel cars and light duty vehicles, but heavy truck crews do their own refueling.

Doses to rail crew and rail escorts are similar. Spent fuel may be transported in dedicated trains so that both escorts and train crew are assumed to be within a distance of one railcar length of the railcar carrying the spent fuel. Escorts in the escort car are not shielded because they must maintain line-of-sight to the railcar carrying spent fuel. Train crew members are in a crew compartment and were assumed to have some shielding, resulting in an estimated dose about 25 percent less than the escort. The largest collective doses are to railyard workers. The number of workers in railyards is not constant and the number of activities that brings these workers into proximity with the shipment varies as well. This analysis assumes the dose to the worker doing an activity for each activity (e.g., inspection, coupling and decoupling the railcars, moving the railcar into position for coupling). The differences between doses in the Rail-Lead case and the Rail-Steel case reflect differences in cask dimensions and in external dose rate.

Truck crew members are shielded so that the largest dose they would receive is  $2.0 \times 10^{-5}$  Sv/hr (2.0 mrem/hr). This regulatory maximum was imposed in the RADTRAN calculation. Truck inspectors generally spend about 1 hour within 1 meter of the cargo (Weiner and Neuhauser, 1992), resulting in a relatively large dose. An upper bound to the duration of a truck refueling stop is about 50 minutes (0.83 hours) (Griego et al., 1996). The truck stop worker whose dose is reflected in Table 13 is assumed to be outside (unshielded) at 15 meters from the truck during the stop. Truck stop workers in concrete or brick buildings are shielded.

## **SUMMARY**

A summary of the results for the incident-free transport of spent fuel in the three casks analyzed in this study are presented in Tables 14, 15, and 16.

A code that estimates risk is never completely precise because the input data are estimates and projections. To account for this imprecision, RADTRAN uses parameter values that overestimate doses. Actual measurements (Steinman, et al., 2000) confirm that RADTRAN overestimates doses by a small margin. Therefore, the doses calculated in this paper should be regarded as overestimates.

The individual and collective doses calculated are for a single shipment and, even though overestimated, they are uniformly very small. Maximum individual doses are comparable to background doses and are less than doses from many medical diagnostic procedures. Collective doses are orders of magnitude less than the collective background dose, as shown in Figure 9 for an example shipment from Maine Yankee to ORNL. This route assumes ten inspection stops at state boundaries. The NRC recommends that collective doses (average doses integrated over a population) only be used for comparisons (NRC, 2008). The proper comparison for collective doses is between the background collective dose plus the shipment dose and the background dose if there is no shipment. The collective dose, however, is never zero in the absence of a shipment.

**Table 14. Total Collective Dose in Person-Sv from Routine Transportation for Each Rail Route for the Rail-Lead Cask**

Origin	Destination	Residents Along Route	Occupants of Vehicles Sharing Route	Residents near Stop	Railyard Crew and Escorts	Total
MAINE YANKEE	ORNL	$2.1 \times 10^{-4}$	$4.0 \times 10^{-5}$	$1.1 \times 10^{-4}$	$3.4 \times 10^{-4}$	$7.0 \times 10^{-4}$
	Deaf Smith	$2.5 \times 10^{-4}$	$6.1 \times 10^{-5}$	$5.3 \times 10^{-5}$	$5.1 \times 10^{-4}$	$8.7 \times 10^{-4}$
	Hanford	$2.9 \times 10^{-4}$	$9.0 \times 10^{-5}$	$1.1 \times 10^{-4}$	$7.6 \times 10^{-4}$	$1.2 \times 10^{-3}$
	Skull Valley	$2.9 \times 10^{-4}$	$7.4 \times 10^{-5}$	$5.4 \times 10^{-5}$	$6.2 \times 10^{-4}$	$1.1 \times 10^{-3}$
KEWAUNEE	ORNL	$1.3 \times 10^{-4}$	$2.7 \times 10^{-5}$	$1.1 \times 10^{-4}$	$2.3 \times 10^{-4}$	$5.0 \times 10^{-4}$
	Deaf Smith	$1.1 \times 10^{-4}$	$3.4 \times 10^{-5}$	$6.8 \times 10^{-5}$	$3.0 \times 10^{-4}$	$5.1 \times 10^{-4}$
	Hanford	$1.1 \times 10^{-4}$	$5.2 \times 10^{-5}$	$1.1 \times 10^{-4}$	$4.7 \times 10^{-4}$	$7.4 \times 10^{-4}$
	Skull Valley	$1.4 \times 10^{-4}$	$4.9 \times 10^{-5}$	$1.2 \times 10^{-4}$	$4.3 \times 10^{-4}$	$7.4 \times 10^{-4}$
INDIAN POINT	ORNL	$1.6 \times 10^{-4}$	$2.7 \times 10^{-5}$	$1.3 \times 10^{-4}$	$2.1 \times 10^{-4}$	$5.3 \times 10^{-3}$
	Deaf Smith	$2.0 \times 10^{-4}$	$5.6 \times 10^{-5}$	$5.9 \times 10^{-5}$	$4.8 \times 10^{-4}$	$8.0 \times 10^{-3}$
	Hanford	$2.5 \times 10^{-4}$	$8.5 \times 10^{-5}$	$1.1 \times 10^{-4}$	$7.2 \times 10^{-4}$	$1.2 \times 10^{-3}$
	Skull Valley	$2.4 \times 10^{-4}$	$6.5 \times 10^{-5}$	$5.6 \times 10^{-5}$	$6.0 \times 10^{-4}$	$9.3 \times 10^{-3}$
INL	ORNL	$1.3 \times 10^{-4}$	$5.7 \times 10^{-5}$	$9.5 \times 10^{-5}$	$5.1 \times 10^{-4}$	$8.0 \times 10^{-4}$
	Deaf Smith	$6.7 \times 10^{-5}$	$3.2 \times 10^{-5}$	$7.7 \times 10^{-5}$	$3.1 \times 10^{-4}$	$4.9 \times 10^{-4}$
	Hanford	$3.6 \times 10^{-5}$	$1.8 \times 10^{-5}$	$5.6 \times 10^{-5}$	$1.8 \times 10^{-4}$	$3.0 \times 10^{-4}$
	Skull Valley	$3.0 \times 10^{-5}$	$8.2 \times 10^{-6}$	$3.1 \times 10^{-6}$	$9.5 \times 10^{-5}$	$1.4 \times 10^{-4}$

**Table 15. Total Collective Dose in Person-Sv from Routine Transportation for Each Rail Route for the Rail-Steel Cask**

Origin	Destination	Residents Along Route	Occupants of Vehicles Sharing Route	Residents Near Stop	Railyard Crew and Escorts	Total
MAINE YANKEE	ORNL	$1.6 \times 10^{-4}$	$3.0 \times 10^{-5}$	$8.5 \times 10^{-5}$	$2.3 \times 10^{-4}$	$5.1 \times 10^{-4}$
	Deaf Smith	$1.9 \times 10^{-4}$	$4.6 \times 10^{-5}$	$5.0 \times 10^{-5}$	$3.7 \times 10^{-4}$	$6.7 \times 10^{-4}$
	Hanford	$2.3 \times 10^{-4}$	$6.8 \times 10^{-5}$	$8.8 \times 10^{-5}$	$5.6 \times 10^{-4}$	$9.5 \times 10^{-4}$
	Skull Valley	$2.2 \times 10^{-4}$	$5.5 \times 10^{-5}$	$4.1 \times 10^{-5}$	$4.5 \times 10^{-4}$	$7.7 \times 10^{-4}$
KEWAUNEE	ORNL	$9.6 \times 10^{-5}$	$2.0 \times 10^{-5}$	$8.3 \times 10^{-5}$	$1.5 \times 10^{-4}$	$3.5 \times 10^{-4}$
	Deaf Smith	$8.3 \times 10^{-5}$	$2.6 \times 10^{-5}$	$5.2 \times 10^{-5}$	$2.1 \times 10^{-4}$	$3.7 \times 10^{-4}$
	Hanford	$8.3 \times 10^{-5}$	$3.9 \times 10^{-5}$	$8.7 \times 10^{-5}$	$3.3 \times 10^{-4}$	$5.4 \times 10^{-4}$
	Skull Valley	$1.1 \times 10^{-4}$	$3.7 \times 10^{-5}$	$9.1 \times 10^{-5}$	$3.0 \times 10^{-4}$	$5.4 \times 10^{-4}$
INDIAN POINT	ORNL	$1.2 \times 10^{-4}$	$2.0 \times 10^{-5}$	$1.0 \times 10^{-4}$	$1.4 \times 10^{-4}$	$3.8 \times 10^{-4}$
	Deaf Smith	$1.5 \times 10^{-4}$	$4.3 \times 10^{-5}$	$4.5 \times 10^{-5}$	$3.4 \times 10^{-4}$	$5.8 \times 10^{-4}$
	Hanford	$1.9 \times 10^{-4}$	$6.5 \times 10^{-5}$	$8.3 \times 10^{-5}$	$5.2 \times 10^{-4}$	$8.6 \times 10^{-4}$
	Skull Valley	$1.8 \times 10^{-4}$	$4.9 \times 10^{-5}$	$4.3 \times 10^{-5}$	$4.4 \times 10^{-4}$	$7.1 \times 10^{-4}$
INL	ORNL	$1.0 \times 10^{-4}$	$4.3 \times 10^{-5}$	$7.2 \times 10^{-5}$	$3.6 \times 10^{-4}$	$5.7 \times 10^{-4}$
	Deaf Smith	$5.2 \times 10^{-5}$	$2.5 \times 10^{-5}$	$5.8 \times 10^{-5}$	$2.1 \times 10^{-4}$	$3.4 \times 10^{-4}$
	Hanford	$2.8 \times 10^{-5}$	$1.4 \times 10^{-5}$	$4.3 \times 10^{-5}$	$1.2 \times 10^{-4}$	$2.0 \times 10^{-4}$
	Skull Valley	$2.2 \times 10^{-5}$	$6.2 \times 10^{-6}$	$2.4 \times 10^{-6}$	$5.0 \times 10^{-5}$	$8.0 \times 10^{-5}$

**Table 16. Total Collective Dose in Person-Sv from Routine Transportation for Each Highway Route for the Truck Cask**

Origin	Destination	Residents Along Route	Occupants of Vehicles Sharing Route	Residents Near Stop	Persons Sharing Stop	Crew/Truck Stop Worker	Total
MAINE YANKEE	ORNL	$9.6 \times 10^{-5}$	$4.6 \times 10^{-4}$	$1.2 \times 10^{-5}$	$8.6 \times 10^{-4}$	$6.8 \times 10^{-4}$	$2.1 \times 10^{-3}$
	Deaf Smith	$1.4 \times 10^{-4}$	$7.3 \times 10^{-4}$	$1.8 \times 10^{-5}$	$9.2 \times 10^{-4}$	$1.4 \times 10^{-3}$	$3.2 \times 10^{-3}$
	Hanford	$1.2 \times 10^{-4}$	$8.3 \times 10^{-4}$	$1.4 \times 10^{-5}$	$1.3 \times 10^{-3}$	$1.9 \times 10^{-3}$	$4.2 \times 10^{-3}$
	Skull Valley	$1.1 \times 10^{-4}$	$7.0 \times 10^{-4}$	$1.4 \times 10^{-5}$	$1.1 \times 10^{-3}$	$1.6 \times 10^{-3}$	$3.5 \times 10^{-3}$
KEWAUNEE	ORNL	$5.2 \times 10^{-5}$	$3.3 \times 10^{-4}$	$6.6 \times 10^{-6}$	$3.2 \times 10^{-4}$	$4.9 \times 10^{-4}$	$1.2 \times 10^{-3}$
	Deaf Smith	$4.7 \times 10^{-5}$	$3.1 \times 10^{-4}$	$5.8 \times 10^{-6}$	$5.7 \times 10^{-4}$	$8.3 \times 10^{-4}$	$1.8 \times 10^{-3}$
	Hanford	$5.1 \times 10^{-5}$	$5.4 \times 10^{-4}$	$6.6 \times 10^{-6}$	$9.0 \times 10^{-4}$	$1.3 \times 10^{-3}$	$2.9 \times 10^{-3}$
	Skull Valley	$3.9 \times 10^{-5}$	$3.8 \times 10^{-4}$	$5.1 \times 10^{-6}$	$6.8 \times 10^{-4}$	$1.0 \times 10^{-3}$	$2.2 \times 10^{-3}$
INDIAN POINT	ORNL	$6.9 \times 10^{-5}$	$4.6 \times 10^{-4}$	$8.3 \times 10^{-6}$	$3.2 \times 10^{-4}$	$4.9 \times 10^{-4}$	$1.3 \times 10^{-3}$
	Deaf Smith	$1.4 \times 10^{-4}$	$6.9 \times 10^{-4}$	$1.4 \times 10^{-5}$	$7.9 \times 10^{-4}$	$1.2 \times 10^{-3}$	$2.9 \times 10^{-3}$
	Hanford	$8.9 \times 10^{-5}$	$7.2 \times 10^{-4}$	$1.2 \times 10^{-5}$	$1.2 \times 10^{-3}$	$1.7 \times 10^{-3}$	$3.9 \times 10^{-3}$
	Skull Valley	$7.7 \times 10^{-5}$	$6.6 \times 10^{-4}$	$1.1 \times 10^{-5}$	$9.5 \times 10^{-4}$	$1.4 \times 10^{-3}$	$3.1 \times 10^{-3}$
INL	ORNL	$6.3 \times 10^{-5}$	$5.0 \times 10^{-4}$	$7.5 \times 10^{-6}$	$8.6 \times 10^{-4}$	$1.3 \times 10^{-3}$	$2.7 \times 10^{-3}$
	Deaf Smith	$3.7 \times 10^{-5}$	$3.4 \times 10^{-4}$	$4.0 \times 10^{-6}$	$6.0 \times 10^{-4}$	$8.8 \times 10^{-4}$	$1.9 \times 10^{-3}$
	Hanford	$1.4 \times 10^{-5}$	$2.0 \times 10^{-4}$	$1.1 \times 10^{-6}$	$2.3 \times 10^{-4}$	$3.7 \times 10^{-4}$	$8.5 \times 10^{-4}$
	Skull Valley	$1.2 \times 10^{-5}$	$8.5 \times 10^{-5}$	$1.2 \times 10^{-6}$	$1.2 \times 10^{-4}$	$1.8 \times 10^{-4}$	$1.6 \times 10^{-3}$

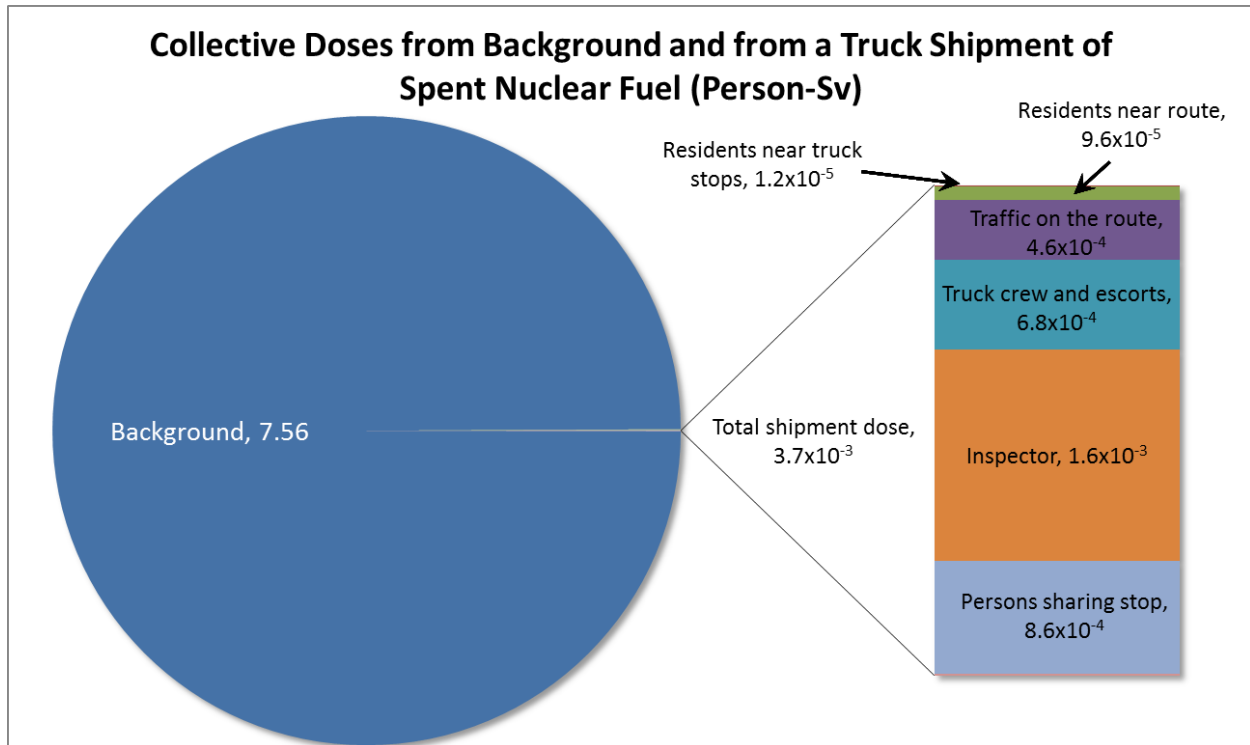

**Figure 9. Collective doses from background and from Maine Yankee to ORNL truck shipments of spent nuclear fuel (person-Sv)**

## BIBLIOGRAPHY

Code of Federal Regulations (CFR) 2009, Volume 10, Part 20 and Part 71

Code of Federal Regulations (CFR) 2009, Volume 49, Part 356

Dennis, M.L., Osborn, D. O., Weiner, R. F., Heames, T.J. 2008. *Verification and Validation of RADTRAN 6.0* SAND2008-4556, Sandia National Laboratories, Albuquerque, NM.

General Atomics. 1998. *Safety Analysis Report for Packaging*, General Atomics Project 4439, San Diego, CA

Griego, N.R.; Smith, J.D.; Neuhauser, K.S. 1996. "Investigation of Radtran Stop Model Input Parameters for Truck Stops," SAND96-0714C. Sandia National Laboratories. Albuquerque, NM.

Holtec International. 2004. *Safety Analysis Report for the HI-STAR* Holtec Report 951251.

Johnson, P.E. and Michelhaugh, R.D. 2003. *Transportation Routing Analysis Geographic Information System (TRAGIS) User Manual*, ORNL/NTRC-006, Oak Ridge National Laboratory, TN.



- Nuclear Acceptance Corporation (NAC) International. 2002. *Safety Analysis Report for the NAC Universal Multi-Purpose Canister System*, NRC Docket 71-9235, Atlanta, GA.
- Neuhauser, K.S., Kanipe, F.L., Weiner, R.F. 2000. *RADTRAN 5, Technical Manual*, Sandia National Laboratories, Albuquerque, NM.
- Sprung, J.L., Ammerman, D. J., Breivik, N.L., Dukart, R.J., Kanipe, F.L., Koski, J. A., Mills, G.S., Neuhauser, K.S., Radloff, H.D., Weiner, R.F., Yoshimura, H.R.. 2000. *Re-Examination of Spent Fuel Risk Estimates* NUREG/CR-6672, Sandia National Laboratories, Albuquerque, NM.
- Steinman, R. L., Weiner, R.F., Kearfott, K. 2002. . “Comparison of Transient Dose Model Predictions and Experimental Measurements.” *Health Physics* v. 83 (2002), p.504 et seq
- Taylor, J.M. and Daniel, S.L 1977. *RADTRAN: A Computer Code to Analyze Transportation of Radioactive Material*, SAND76-0243, Sandia National Laboratories, Albuquerque, NM.
- U.S. Department of Energy (DOE ). 2002 *Final Environmental Impact Statement for a Geologic Repository for the Disposal of Spent Nuclear Fuel and High-Level Radioactive Waste at Yucca Mountain, Nye County, Nevada*. DOE/EIS-0250F, Washington, DC, Chapter 6 and Appendix J..
- U.S. Department of Transportation (DOT). 2004a. “Maximum Posted Speed Limits by Type of Road,” (Table 2-9) Bureau of Transportation Statistics Research and Innovative Technology Administration, Washington, DC
- U.S. Department of Transportation (DOT). 2004b. “Rail freight Average Speeds, Revenue Ton-Miles, and Terminal Dwell Times” (Table 2-9) Bureau of Transportation Statistics Research and Innovative Technology Administration, Washington, DC
- U.S. Department of Transportation (DOT). 2007. “Traffic Safety Facts 2007” (Tables 1-32, 2-03, 2-04, 2-09, 2-28, 2-37) Bureau of Transportation Statistics Research and Innovative Technology Administration, [www.bts.gov](http://www.bts.gov), Washington, DC
- U.S. Department of Transportation (DOT). 2009. “Commodity Flow Survey: Shipment Characteristics by Mode of Transportation for the U.S., 2007” (Table1) Bureau of Transportation Statistics Research and Innovative Technology Administration, Washington, DC
- U.S. Department of Transportation (DOT). 2008. National Transportation Statistics 2008, Bureau of Transportation Statistics , Research and Innovative Technology Administration, Washington, DC  
[http://www.bts.gov/publications/national\\_transportation\\_statistics/html/table\\_02\\_23.htm](http://www.bts.gov/publications/national_transportation_statistics/html/table_02_23.htm)
- U. S. Nuclear Regulatory Commission (NRC). 1977. *Final Environmental Statement on the Transportation of Radioactive Material by Air and Other Modes*, NUREG-0170, U.S. Nuclear Regulatory Commission, Washington, DC.

U. S. Nuclear Regulatory Commission (NRC). 2012. Spent Fuel Transportation Risk Assessment, NUREG-2125, Draft for Public Comment, U.S. Nuclear Regulatory Commission, Rockville, MD.

Weiner, R.F., Dennis, M.L. Hinojosa, D., Heames, T.J., Penisten, J.J., Marincel, M.K., Osborn, D.M. 2009. *RadCat 3.0 User Guide*, SAND2009-5129P. Sandia National Laboratories, Albuquerque, NM

Wooden, D.G. 1986. *Railroad Transportation of Spent Nuclear Fuel* SAND86-7083, Sandia National Laboratories, Albuquerque, NM