

CRITICALITY SAFETY OF ENRICHED UF₆ CYLINDERS

L. Begue
IRSN - France

M. Milin
IRSN - France

G. Caplin
IRSN - France

S. Evo
IRSN - France

ABSTRACT

The transport of enriched hexafluoride uranium (UF₆) is carried out in large steel cylinders. In filled cylinders, a maximum of 0.5wt. % of impurities is assumed to be present in UF₆. Usually, for nuclear criticality safety studies, these impurities are supposed to be HF and the cylinders content is then modeled by a UF₆-0.1HF medium completely filling the cavity. The aim of this paper is to highlight parameters which have a significant and non-intuitive impact on reactivity and to present an evolution of the nuclear criticality safety assessment by taking into account uranium residues like UO₂F₂ in filled UF₆ cylinders.

The first part of this paper focuses on three main parameters (uranium mass, interstitial moderation between cylinders, cylinders steel wall thickness) which have an impact on reactivity. The calculations are performed for an infinite array of 30B cylinders (30 inches diameter) containing enriched UF₆ up to 5wt. % of ²³⁵U. The main conclusions of this part are:

- the maximum of reactivity is reached when cylinders are not entirely filled with UF₆,
- the interstitial moderation combined with a gap between cylinders lead to increase reactivity.

Moreover, some air in-leakage in cylinders is possible and its moisture content results in the hydrolysis of UF₆ and creation of non-volatile uranium residues, in particular UO₂F₂ complexes with H₂O and HF. Because cylinders are not washed before each transport, the accumulation of such residues is possible in the cylinders.

So, the second part of the study deals with the conservative composition of these residues in regard to reactivity and compares the reactivity of the packaging with and without their presence. According to scientific literature, the ratio H/U in UO₂F₂ complexes is variable. Furthermore, the mass of uranium residues depends on the amount of air moisture in-leakage in a cylinder which is difficult to quantify. The approach presented in this paper considers calculations with various spherical masses of UO₂F₂ per package with various H/U ratios surrounded by UF₆-0.1HF. The results of these calculations show that the presence of uranium residues can increase considerably the reactivity of the packaging (depending on the H/U ratio in the complex residues).

INTRODUCTION

The packaging and transport of UF₆ are performed in accordance with the standards ISO 7195 [1] and ANSI N14.1 [2] which provide safety requirements and assist all stakeholders in the nuclear industry. These standards present various designs of UF₆ cylinders. This article deals with the most used type of cylinders, the 30 inches cylinder containing UF₆ enriched up to 5wt.% of ²³⁵U. As shown on figure 1, the 30 inches cylinder (cylinder 30B for example) is a right circular cylinder and

is made of carbon steel. Generally, it is transported in an overpack (shielding) to protect the cylinder (and in particular the drain plug) against mechanical and thermal effects in case of an accident during the transport.

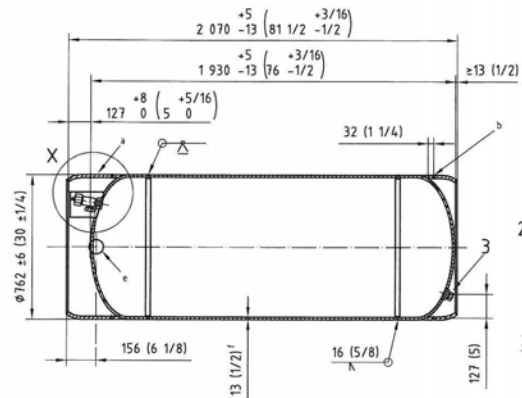

Figure 1. Picture and sketch of UF₆ cylinder 30B (dimensions in cm and inches)

UF₆ is shipped in solid phase and is transformed in gas or liquid phase to be processed in nuclear facilities. The mass limit in a cylinder, according to the requirements of the standard [1], is based on the UF₆ liquid density at 394K (3257 kg/m³ compared to the solid density which is 5090 kg/m³ at 294K), on the minimum internal volume of the cylinder (0,736 m³) and on a minimum required free space in the cylinder of 5 %. So, the maximum fill limit for a 30 inches cylinder is 2277 kg of UF₆.

The minimum purity of UF₆ has to be equal to 99.5 % according to the standards. All the remaining compounds (0.5 % in mass) which are allowed in the content (for “product quality” concerns) are volatile compounds, such as the hydrofluoric acid gas (HF). However, during the use of UF₆ cylinders, non volatile products of uranium reactions may be created (the so-called residues), in particular uranyl fluoride compounds (UO₂F₂) which are one of the products of UF₆ hydrolysis.

The nuclear criticality safety of UF₆ enriched cylinders is based on the geometrical dimensions and on a limited moderation of the content.

This article presents the main parameters which have an impact on the nuclear criticality safety analysis for an infinite number of UF₆ filled 30 inches cylinders, in particular in presence of residues of uranium in the cylinders. In all the calculations, uranium content in ²³⁵U is 5 % by weight. Calculations are performed using the standard route APOLLO2-MORET 4 of the CRISTAL V1 package [3], associated with the JEF 2.2 nuclear data library.

ASSESSMENT OF FILLED CYLINDERS

Criticality safety practice usually takes into account hydrofluoric acid (HF) as the only impurity in UF₆ to assess nuclear criticality safety of filled cylinders. In the first part of this paper, only these volatile impurities are considered.

In order to account for the minimum UF₆ purity of 99.5 %, a ratio H/U equal to 0.088, rounded to 0.1, is fixed in the homogeneous fissile mixture (UF₆-0.1HF).

Impact of the UF₆ mass and the interstitial moderation

The assumptions for this first study are the following:

- cylinders are modeled by a cylindrical cavity made by a 7.94 mm steel thickness;
- the content is modeled by a homogeneous fissile mixture (UF₆-0.1HF) at varying density in the entire internal cavity;
- the moderation between cylinders is modeled by a varying layer of water around each cylinder;
- the calculations are based on an infinite array of cylinders by applying a reflection directly on the water layer of one cylinder.

The calculation model is illustrated on the figure 2a below and covers an infinite array of cylinders (as represented on the figure 2b). The variation of the UF_6 density in the entire internal cavity allows to make vary the UF_6 mass in the cylinder. Moreover, this model can represent the variation of the UF_6 density during the change of phases (solid or liquid). The modeling of a variable layer of water directly on the steel thickness and a reflection permits to cover the presence of water or miscellaneous hydrogenous products between cylinders in the array.

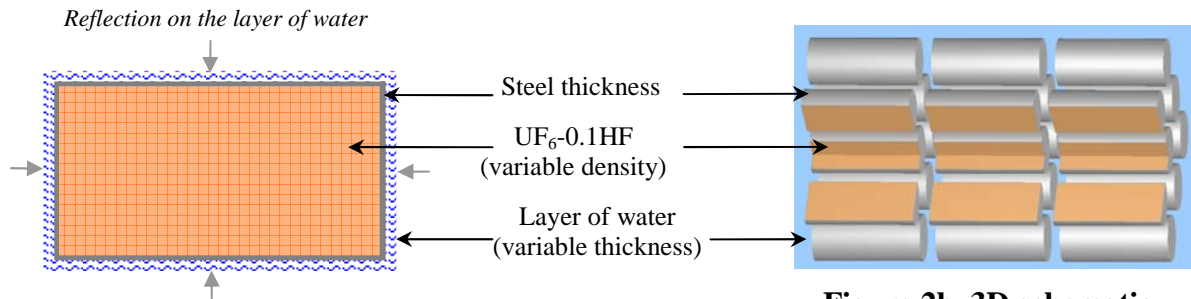

Figure 2a. Calculation model

Figure 2b. 3D schematic representation of the array

The results of the calculations, illustrated on figure 3, present the variation of the effective multiplication factor (k_{eff}) as a function of the mass of UF_6 in each cylinder and the moderation between cylinders (varying thickness of a water layer around each cylinder). Cylinders are in contact when the layer of water is null and spaced out otherwise. The ratio between the UF_6 density in the calculation and the maximal UF_6 density is named “filling ratio”. When this ratio is equal to 1, the modeled mass of UF_6 is equal to 3620 kg. The maximal allowed mass of UF_6 specified by ISO 7195 (2277 kg) is obtained for a filling ratio of 0.63.

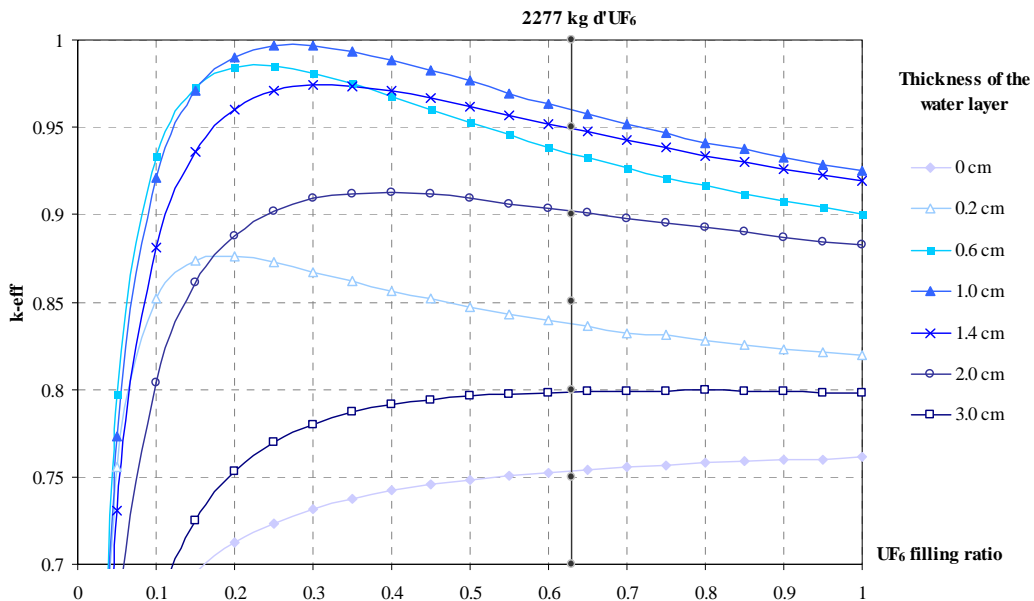

Figure 3. Mass of UF_6 and interstitial moderation impact on reactivity

The previous graph shows that the highest reactivity is obtained when cylinders are surrounded by a layer of water and partially filled of UF_6 . In this example, the k_{eff} is under 0.80 without a layer of water around the cylinders and reaches 1 (critical^(a)) when the water layer is 1 cm thick. In this case, corresponding to the optimal interstitial moderation between cylinders, the maximum of reactivity is obtained for an UF_6 filling ratio close to 0.3. For a filling ratio of 0.63 (corresponding to the actual maximal amount of UF_6 allowed per cylinder), the maximal value of

reactivity is equal to ~ 0.96 , that is 4 %^(b) higher than the maximal reactivity for completely filled cylinders.

These results could be firstly explained by the following qualitative analysis: The increase of the water layer thickness between cylinders improves the neutron slowing down effect and the number of fission reaction in the fissile medium. This phenomenon is improved by increasing the neutron flow reaching the water layer by decreasing the density of the fissile medium.

This simple explanation could be verified by considering some main neutronic parameters. Indeed, the k_{eff} is the result of the ratio between the number of produced neutrons on absorbed neutrons in this infinite system (no neutron leakage). Figures 4 and 5 illustrate the variation of these two parameters in function of the UF_6 filling ratio and the thickness of the water layer between the cylinders.

Figure 4a, obtained with a water layer of 1 cm, shows that the ratio between productions and absorptions of neutrons in the fissile medium (k_{inf}) increases with the UF_6 density diminution in the cylinders. This UF_6 mass diminution involves the increase of neutron leakage out of the cylinders and thus an improvement of the slowing down of neutrons in the water layer as shown on figure 4b with the decreasing curve of the energy corresponding to average lethargy of neutrons causing fission (EALF). This effect is obviously limited by the decrease of the absorption rate of neutron in the fissile medium (a part of which is causing fissions) and by the increase of the absorption rate (capture) in the water layer and in the steel shell, as shown on the figures 4a and 4c. Thus, the combination of these effects involves an optimum of k_{eff} for an UF_6 filling intermediate ratio (around 0.3).

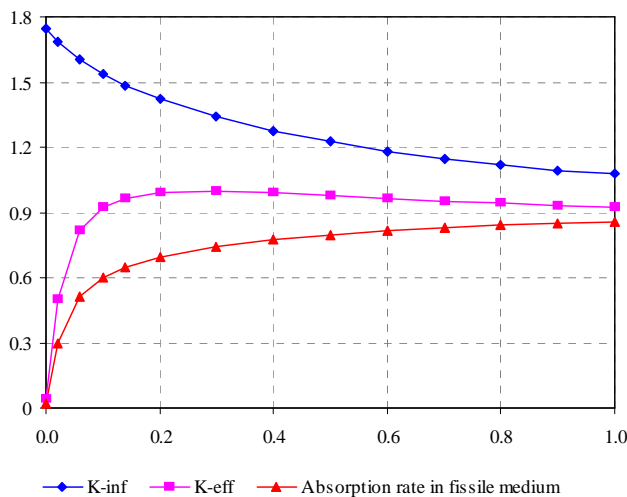

Figure 4a. Neutronic parameters vs UF_6 filling ratio (thickness of water layer = 1 cm)

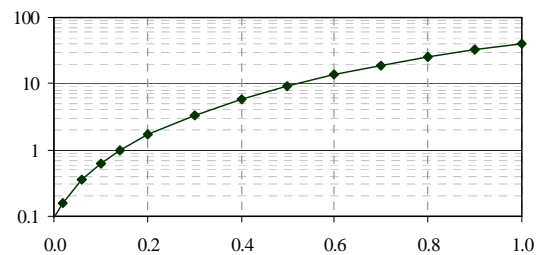

Figure 4b. EALF (eV) vs UF_6 filling ratio

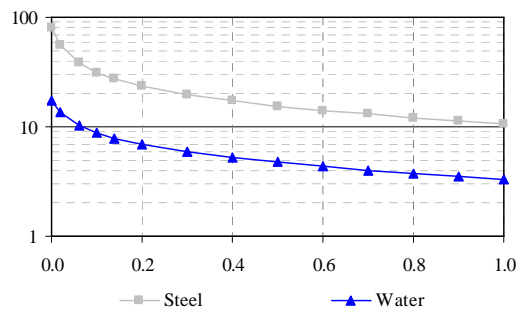

Figure 4c. Absorption in materials (%) vs UF_6 filling ratio

Regarding now the effect of the water layer thickness (which provides the moderation of the neutrons, as seen previously), the figure 5a, obtained with a filling ratio of 0.3, shows that the ratio between productions and absorptions of neutrons in the fissile medium (k_{inf}) increases with the thickness of the water layer. Figure 5b below shows that for a small thickness of the water layer, the EALF is in the epithermal range whereas, for larger layers, the EALF is in the thermal range. This effect is compensated, as showed on figures 5a and 5c, by:

- the increase of neutron absorptions in the water layer and in the steel shell as the slowing down of the neutrons is better due to the increase of the water quantity between cylinders;
- the absorption rate of the neutrons in the fissile medium (a part of which is causing fissions) which decreases in the same time.

Thus, the combination of these effects involves an optimum of k-eff around a thickness of the water layer of 1 cm (space between cylinders of 2 cm).

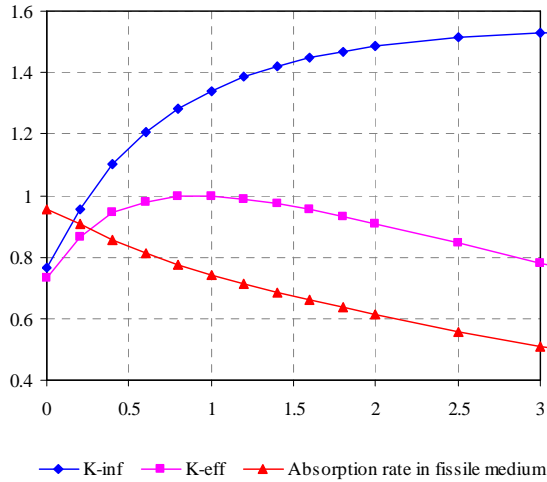

Figure 5a. Neutronic parameters vs the water layer thickness in cm (UF₆ filling ratio = 0.3)

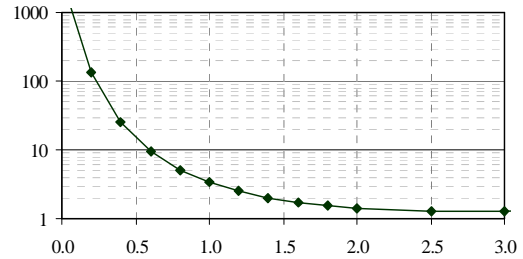

Figure 5b. EAFI (eV) vs the water layer thickness in cm

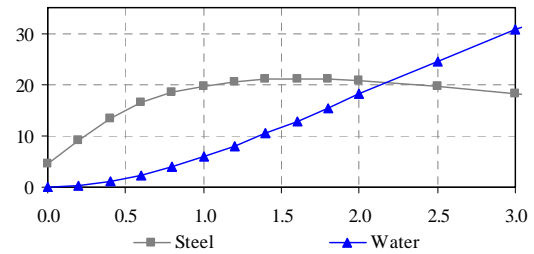

Figure 5c. Absorption in materials (%) vs the water layer thickness in cm

Impact of the modeling of UF₆ in cylinders

A second way is possible to represent the varying mass of UF₆ in the cylinders, by varying the UF₆ crust (at the maximum density) on the cylinders walls. This model is illustrated on the figures 6a and 6b below.

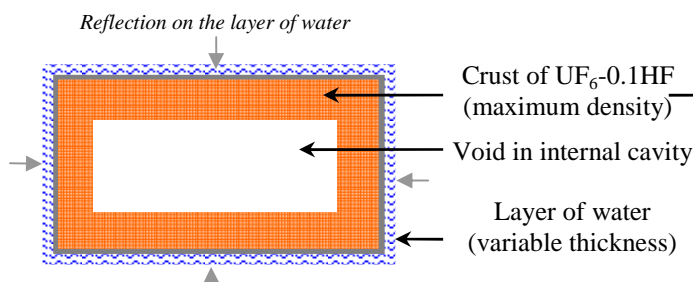

Figure 6a. Calculation model

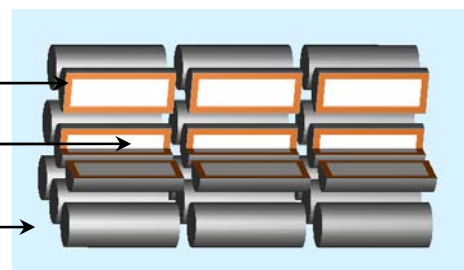

Figure 6b. 3D schematic representation of the array

The results of this other modeling are illustrated on the figure 7 below and are compared with the previous case with a variable density of UF₆ (i.e Figures 2a and 2b), as a function of the mass of UF₆. This comparison is made for the optimal interstitial moderation (optimal water layer thickness between cylinders).

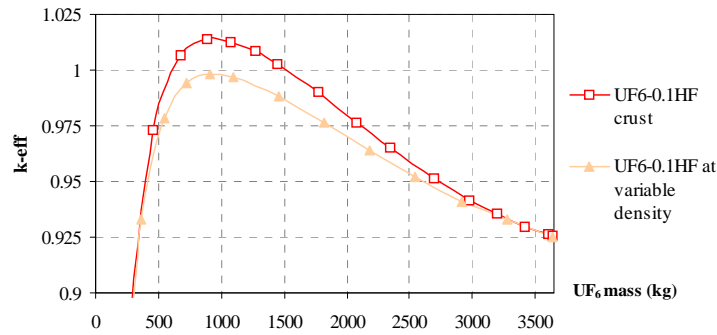

Figure 7. Impact of the UF₆ mass on reactivity

The maximum reactivity is higher for the model with a crust of UF₆ than for the low UF₆ density model. The difference between these two models is about 1.5 %^(b) and the underlying hypotheses of the crust modeling could not be considered as “incredible” because UF₆ is shipped and stored in solid phase. **This last model should be part of the nuclear criticality safety assessment.**

Impact of steel thickness on k-eff

In the previous calculations, the cylinders wall is modeled by a 7.94 mm thickness of steel which is the minimum steel thickness which should be guaranteed according to ISO 7195 [1]. As showed on the figure 1, the nominal thickness in the design plans is 12.7 mm. Moreover, during transport, an overpack, made of foam enclosed by steel plates, is placed around the cylinder.

The impact of this parameter on reactivity is studied by plotting the variation of the reactivity in function of the UF₆ filling ratio for three different steel thicknesses (7.94 mm, 10 mm and 12.7 mm). The results of this study are illustrated on the figure 8 below.

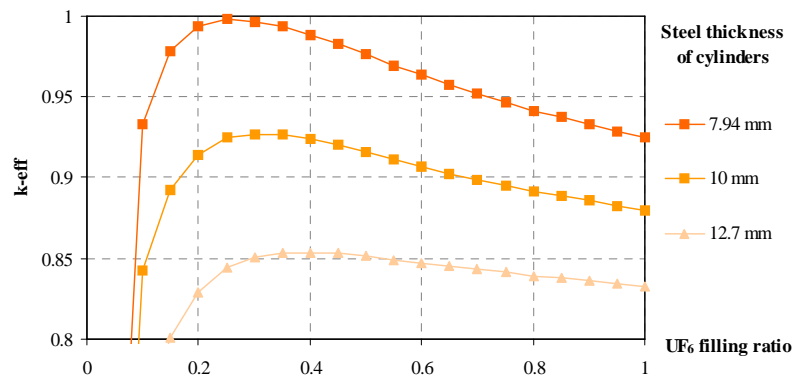

Figure 8. Steel thickness impact on reactivity

The results of the calculations show that the steel thickness around the fissile material has a significant impact on the reactivity. For example, the impact on reactivity between 7.94 mm and 10 mm of steel or between 10 mm and 12.7 mm for each cylinder is a decrease around 7 %^(b). Indeed, steel is an absorbent material for the neutrons. **Consequently, the thickness of steel of UF₆ cylinders is an important parameter allowing to decrease the reactivity. However, it should be kept in mind that the thickness of steel considered in the nuclear criticality safety assessment has to be guaranteed during lifecycle of the UF₆ cylinders.**

IMPACT OF UO₂F₂ RESIDUES IN FILLED CYLINDERS

UF₆ cylinders have to be cleaned before undergoing various tests and controls, at least every five years. The purpose of cleaning is to remove all residues from the cylinders. These residues are grease, slag, oxides, dirt and other foreign matters. Many of them are insoluble and non volatile

reaction products of uranium, like UF_5 (formed by the reaction between iron and UF_6), UF_4 (formed by the reaction $2 UF_5 \rightarrow UF_4 + UF_6$) and uranyl fluoride solids (UO_2F_2) formed by hydrolysis reaction between gaseous of UF_6 and moisture introduced by air leakage ($UF_6 + 2H_2O \rightarrow UO_2F_2 + 4HF$). From a nuclear criticality safety point of view, it is assumed that these last residues (UO_2F_2) bound all the others non volatile reaction products of uranium (UF_5 , UF_4) because of the existence of hydrated compounds of UO_2F_2 .

In current criticality studies, the presence of UO_2F_2 residues is taken into account for empty cylinders which contain a residual amount of UF_6 and non volatile reaction products of uranium in quantities less than those specified in standards [1] and [2] (the so-called "heel"). In this case, the content of empty cylinders is modeled by a limited mass of UO_2F_2 hydrated by any quantity of water. Generally, these uranium residues are not taken into account in filled cylinders. To upgrade the safety approach, the second purpose of this article is to show in which conditions the presence of these residues could be reasonably neglected. For this, it is first necessary to found in chemical literature the possible compositions of UO_2F_2 residues products and then to make calculations of k-eff to estimate the impact of a varying mass and composition of hydrated compounds of UO_2F_2 in filled UF_6 cylinders.

Origin and characteristics of uranium residues

The hydrolysis reaction is due to small introduction of air moisture in UF_6 cylinders (under the atmospheric pressure) during engagement (or accosting) and disengagement for the filling or the extraction of UF_6 and during long storage periods. In this case, the available quantity of water in the cylinder is low (for the UF_6 hydrolysis reaction) in comparison to the UF_6 content. According to the scientific literature, experiments show that the products of hydrolysis reaction between UF_6 (gaseous) and H_2O (vapour) are gaseous HF and a solid complex $UO_2F_2 \cdot xH_2O \cdot yHF$ in which x and y ratios are variable in function of experimental conditions. In criticality safety assessment, it could be assumed (by conserving the same H/U ratio) a bounding material $UO_2F_2 \cdot (x+y/2)H_2O$ to model these uranium residues. The main issue is to have a conservative approach to define the maximum credible ratio H/U ($2x+y$).

When looking in details at the scientific literature, it can be shown that only few results are dedicated to the composition of the direct products of the UF_6 hydrolysis reaction (there are mainly either the hydration of anhydrous UO_2F_2 by a vapour of H_2O , either the reaction between hydrated UO_2F_2 and HF). For example, one of these [4], shows that the formula of the complex produced by the reaction between water and UF_6 (gas) is $UO_2F_2 \cdot 1.3H_2O \cdot 0.35HF$ (the ratios x and y are average values). It is difficult to conclude from these results only, especially knowing that the experimental conditions are not sufficiently detailed.

Regarding experiments about the hydration of anhydrous UO_2F_2 , the operating conditions are generally the reaction of air moisture on samples of anhydrous UO_2F_2 . In the document [5], the hydrated complexes observed are from $UO_2F_2 \cdot 1.86H_2O$ up to $UO_2F_2 \cdot 4H_2O$. The experiments show that this last complex, formed in case of high humidity content on small samples, loses water after a long time in ambient air, to become a more stable complex $UO_2F_2 \cdot 2H_2O$. A diagram of the different $UO_2F_2 \cdot xH_2O$ forms in function of the temperature and the H_2O pressure results from these experiments. This diagram shows that, at 298K, four different hydrated complexes exist (UO_2F_2 , $UO_2F_2 \cdot 2H_2O$, $UO_2F_2 \cdot 2.5H_2O$ and $UO_2F_2 \cdot 4H_2O$), but at 308K and 350K, the highest hydrated complex is respectively $UO_2F_2 \cdot 2.5H_2O$ and $UO_2F_2 \cdot 2H_2O$. The existence of the upper hydrate ($UO_2F_2 \cdot 4H_2O$) is also approached in the bibliographical study of the document [6] which references the results of Brooks investigations [7]. In the document [8], others experiments show that the hydration of low thickness samples of anhydrous UO_2F_2 by air moisture (relative humidity inferior or equal to 90 %) could lead to the formation of a complex $UO_2F_2 \cdot 4H_2O$ non stable which evolves towards the stable complex $UO_2F_2 \cdot 1.5H_2O$ (after several hours). The hydration of higher

thickness samples of anhydrous UO_2F_2 by air moisture shows the direct formation of the stable complex $\text{UO}_2\text{F}_2 \cdot 1.5\text{H}_2\text{O}$, without higher hydrated composition (in average for the sample). **Thus, the results of the main experiments about UO_2F_2 complexes show that the hydration of UO_2F_2 in presence of air moisture should not be higher than $\text{UO}_2\text{F}_2 \cdot 4\text{H}_2\text{O}$, with a stable form around $\text{UO}_2\text{F}_2 \cdot 2\text{H}_2\text{O}$.**

Regarding experiments carried out on the action of gaseous HF on different hydrated UO_2F_2 solids, results presented in the document [5] show that this type of reaction is slow. The reaction of gaseous HF on the $\text{UO}_2\text{F}_2 \cdot 2\text{H}_2\text{O}$ (at 298K) gives the complex $\text{UO}_2\text{F}_2 \cdot 2\text{H}_2\text{O} \cdot 2\text{HF}$, which is similar to the product obtained by Brooks experiments [7]. The experiments presented in the document [5], carried out on two others hydrated complexes $\text{UO}_2\text{F}_2 \cdot 3\text{H}_2\text{O}$ and $\text{UO}_2\text{F}_2 \cdot 4\text{H}_2\text{O}$, show the formation respectively of $\text{UO}_2\text{F}_2 \cdot 3\text{H}_2\text{O} \cdot 2.44\text{HF}$ and $\text{UO}_2\text{F}_2 \cdot 4\text{H}_2\text{O} \cdot 3\text{HF}$ complexes. The author observed that these last complexes are not stable (quick decomposition). **So, when the hydrolysis reaction of UF_6 is due to the introduction of a small quantity of air moisture in a UF_6 cylinder, the formation of a limited hydrated complex of UO_2F_2 is observed by different experiments. The ratio H/U in the complex $\text{UO}_2\text{F}_2 \cdot x\text{H}_2\text{O} \cdot y\text{HF}$ depends on the conditions of the use of the UF_6 cylinders in the fuel cycle facilities and during the transport. Without specific arrangements to guarantee a maximum quantities of air moisture in-leakage in the cylinders and their conditions of use during their lifecycle (temperature, pressure...), it is difficult to know the maximum H/U ratio ($2x+y$). However, regarding the current experimental knowledge, it can be assumed that this ratio is surely lower than 11 in $\text{UO}_2\text{F}_2 \cdot x\text{H}_2\text{O} \cdot y\text{HF}$ residues.**

In order to cover uranium residues in filled UF_6 cylinders, calculations are carried out to study the impact of these residues in function of their composition and mass.

Impact of uranium residues on reactivity

The mass and the moderation ratio H/U of uranium residues depending strongly on the way they are created, it is interesting to study their impact on reactivity. This comparison is performed for 10 mm steel thick cylinders filled with $\text{UF}_6 \cdot 0.1\text{HF}$ at variable density. Interstitial moderation between cylinders is modeled by a layer of water around the cylinder (the thickness of the layer is chosen in order to reach the maximum k-eff). Uranium residues are modeled by a sphere of $\text{UO}_2\text{F}_2 \cdot (x+y/2)\text{H}_2\text{O}$ in one "corner" of the cylinder, which is the most reactive configuration (maximization of neutron interactions). The figures 9a and 9b show a sketch of the calculation model and a 3D representation of the associated array.

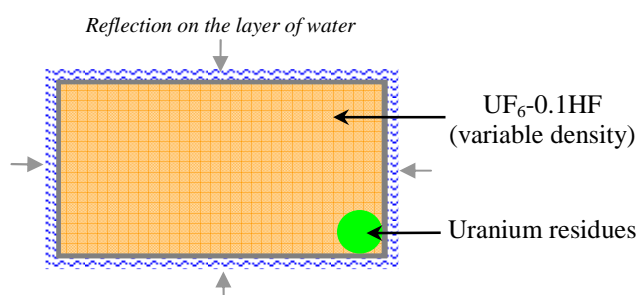

Figure 9a. Calculation model

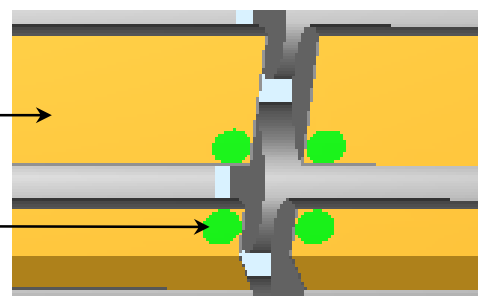

Figure 9b. 3D Representation of the array

Figure 10 shows the increase of the maximum reactivity whatever the UF_6 filling ratio is, due to uranium residues mass and ratio H/U in the $\text{UO}_2\text{F}_2 \cdot (x+y/2)\text{H}_2\text{O}$ medium (i.e. $\text{H/U} = 2x+y$). Δk_{eff} is the difference between the k-eff of an array of cylinders with uranium residues and an array of cylinders without uranium residues.

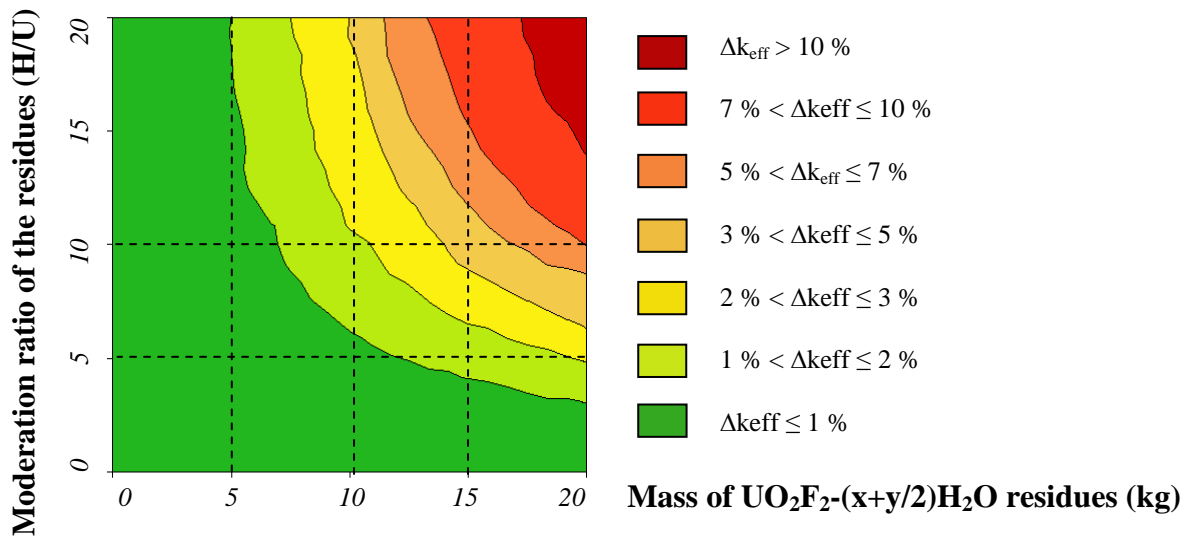

Figure 10. k-eff increase due to uranium residues

From this figure, it can be noted that:

- impact of uranium residues on the reactivity of UF_6 cylinders depends on the mass and on the moderation ratio (H/U) of residues;
- a mass of uranium residues lower than 5 kg per cylinder or a moderation ratio H/U (i.e. $(2x+y)$ in $UO_2F_2-(x+y/2)H_2O$) in uranium residues lower than 3 have a limited impact on reactivity (less than 1 %);
- for a mass of uranium residues per cylinder lower than 11.4 kg (which corresponds to the allowed limit of “heel” for the 30 inches “empty” cylinder transport), the impact on reactivity of residues is higher than 1 % when the moderation ratio (H/U) in uranium residues is higher than 5;
- for a moderation ratio (H/U) in uranium residues lower than 11, the impact on reactivity of residues is higher than 1 % when the mass of uranium residues per cylinder is higher than 6 kg.

Figure 11 below shows the impact of uranium residues on reactivity of UF_6 cylinders for various masses and moderation ratios in function of the UF_6 filling ratio in cylinders.

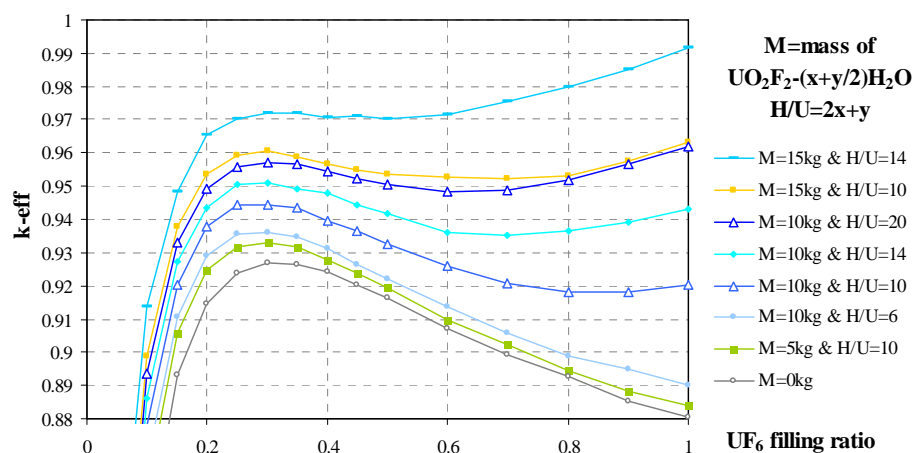

Figure 11. Uranium residues impact on reactivity

From this figure, it is interesting to note the following points:

- for small masses and/or moderation ratios of uranium residues, the increase on reactivity due to these residues is limited and the maximum of reactivity is obtained for an intermediate UF_6 filling ratio (around 0.3); in this case, the presence of uranium residues do not significantly change the overall behavior of the cylinders reactivity.
- for high masses and moderation ratios of uranium residues, the maximum of reactivity shifts to the maximum UF_6 filling ratio. However, this effect seems to be significant only for uranium residues masses higher than the allowed limit of “heel” for the 30 inches “empty” cylinders and higher than the credible H/U assumed (11).

These results highlight the need to have more knowledge on the composition and on the mass of hydrated uranium residues in filled or partially filled cylinders. However, presently a maximum mass of UO_2F_2 residues can't be guaranteed by a weighing of a filled cylinder which contained some metric tons of UF_6 . The current scientific literature and partially knowledge on these residues are not sufficient to conclude on a specific reasonably bounding composition of them. As shown by the calculations results, a specific area (a mass lower than 10 kg or a ratio H/U lower than 5) appears where the impact of residues on the reactivity of UF_6 cylinders can be neglected if specific arrangements (a feedback of the use of the cylinders, additional experiments and analysis on the products of the hydrolysis reaction, specific conditions of use of the cylinders...) are provided to guarantee the boundaries of this area.

CONCLUSIONS

This article shows that the uranium mass per cylinder, the interstitial moderation between cylinders and the cylinders steel wall thickness are three main parameters which should be studied in the nuclear criticality safety assessment of filled UF_6 cylinders. Moreover, an evolution of assessment is presented by taking into account hydrated uranium residues produced by the hydrolysis of UF_6 due to air moisture in-leakage in cylinders. These residues should be assumed to be hydrated compounds of UO_2F_2 . The results of calculations show that the presence of uranium residues can increase considerably the UF_6 cylinders reactivity (depending on the H/U ratio in the residues and on their mass). The safety issues are on the control of the mass and the composition of hydrated uranium residues in filled or partially filled cylinders. A specific area (maximum mass or ratio H/U of hydrated residues) appears where the impact of residues on reactivity of UF_6 cylinders can be neglected. Thus, it seems necessary to deepen the knowledge on the composition and on the mass of hydrated uranium residues in the UF_6 enriched cylinders to justify the criticality safety margins.

END NOTES:

(a): corresponding to the infinite array of cylinders which is conservative from the nuclear criticality safety point of view.

(b): percent in Δk_{eff} .

REFERENCES

[1] INTERNATIONAL ORGANIZATION FOR STANDARDIZATION, Packaging of Uranium Hexafluoride (UF_6) for Transport, ISO 7195:2005 (F), ISO, Geneva (2005).

[2] AMERICAN NATIONAL STANDARDS INSTITUTE, “American National Standard for Nuclear Materials – Uranium Hexafluoride – Packaging for Transport”, ANSI N14.1 – 2001, ANSI, USA (2001)

- [3] GOMIT, J.M., et al., "CRISTAL V1: Criticality package for burn up credit calculations", Proc. Int. Conf. on Nuclear Criticality Safety ICNC2003, Tokai-Mura, Japan, Oct. 20-24 (2003).
- [4] H.E. Eduljee, B.R.348A, ICI Ltd, "The reaction between water and uranium hexafluoride and the action of heat on the reaction product" (1943).
- [5] G. NEVEU, Report CEA 2106, "Etude des composés $UO_2F_2-H_2O-HF$ " (1961).
- [6] F. MORATO, Thèse de l'université de Montpellier II (1997), F. MORATO, "Contribution à l'étude de la réduction de l'uranium. De UF_6 à UO_2 par pyrohydrolyse et action du dihydrogène" (1997).
- [7] BROOKS, GARNER, WHIEEHEAD, IGR-TN/CA-277, U.K.A.E.A. (1958).
- [8] UKAEA DEG, Report 352 (CA), "The hydrates of uranyl Fluoride" (1963).