

SOFT-SIDED PACKAGING FOR LOW LEVEL RADIOACTIVE WASTES

MR. STUART BOWE, MANAGING
DIRECTOR, PACTEC EPS LTD

PATRAM 2010

5 OCTOBER 2010

INTRODUCTION



- Half-height ISO containers (HHISO) have been used successfully for several years in the UK for LLW services
- With the NDA decommissioning programme, much greater quantities of LLW, VLLW, deconstruction debris and contaminated soils are expected
- The LLWR PBO contract requires the identification and evaluation of more efficient, less costly packaging solutions
- Cost, weight, handling difficulties and other factors suggest that other packaging systems should be evaluated

INTRODUCTION



- Soft-sided packages are engineered products and are tested and certified under IAEA standards for VLLW & LLW
- More than 25,000 such packages safely used for storage, transport and disposal of LLW, and other non-radioactive hazardous waste
- Innovations in waste packaging are needed due to the increased volumes
- The slides that follow compare the HHISO with comparable soft-sided waste packages

SOFT SIDED PACKAGE DESIGN & FEATURES



- Soft sided packages like HHISO's have been tested to meet IAEA certification, IP-1, IP-2
- Soft-sided packages are fabricated under strict quality controls in ISO manufacturing facilities
- Soft-sided waste packages come in many shapes, sizes, and have varied applications

SOFT SIDED PACKAGE DESIGN & FEATURES



- LLWR is developing a reusable transport system for soft sided packaging, TC-11, being discussed in another session
- The LLWR IP-1 soft sided design has been tested to demonstrate no loss or dispersal of contents during RCT (routine conditions of transport)

Soft-Sided Waste Package CONSTRUCTION

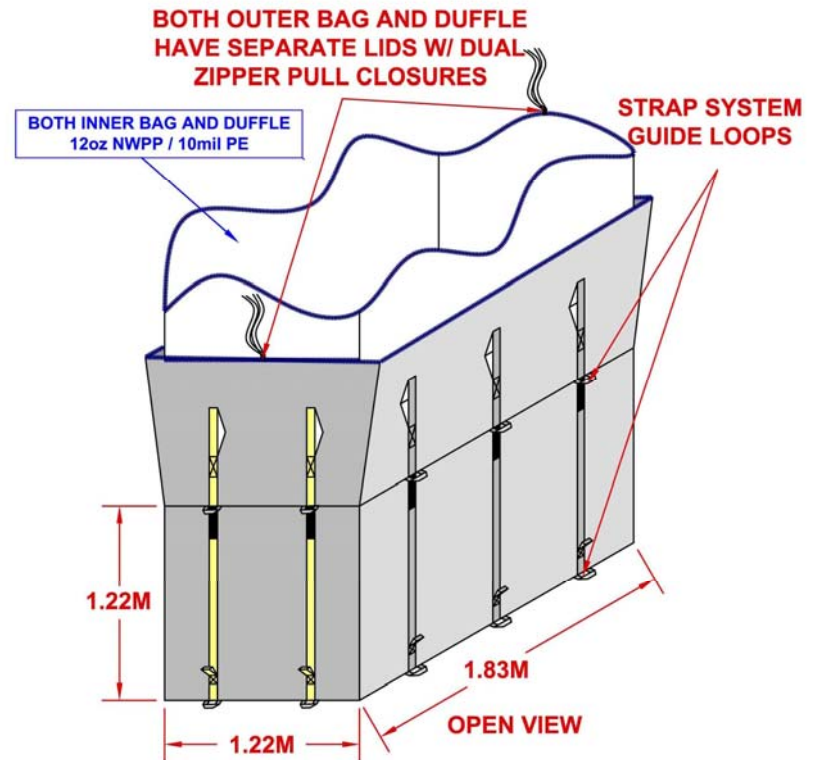
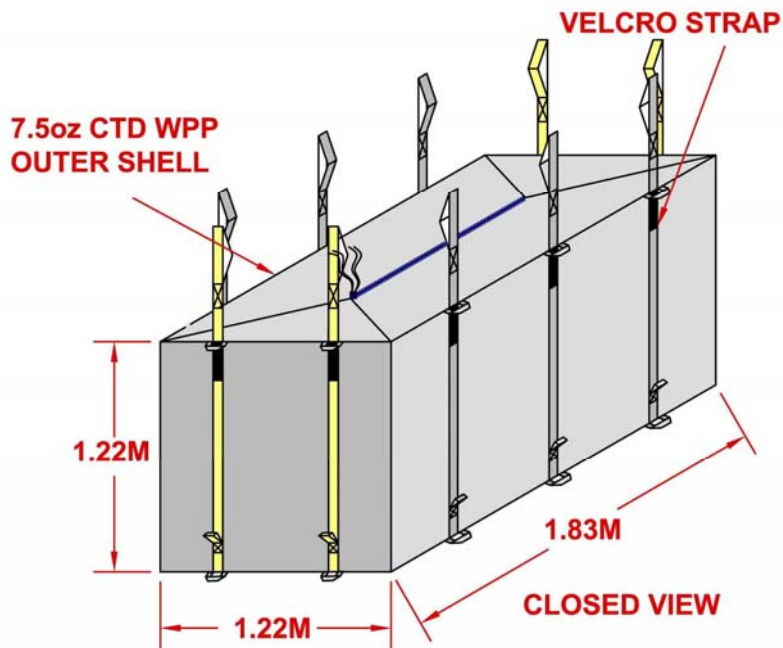

APPLICATIONS



- Soft-sided packages are anticipated to be used primarily for Very Low Level Waste (VLLW), and are certified for construction debris
- Soft-sided packages conform, to some extent, to the space they are placed in

APPLICATIONS



- Other applications for soft sided packaging include Low Specific Activity (LSA) and Surface Contaminated Objects (SCO) wraps



- Demolition debris bags fit large tipper wagons which are used for transport and disposal of contaminated demolition rubble

TESTING



- Recent vibration and pressure tests were performed at Wyle Laboratories in the USA
- Vibration profile was taken from “TCSC 1006 The Securing/Retention of Radioactive Material Packages of Conveyance”
- Gravatom’s methodology the Effects of Ambient Weather Conditions was used to simulate pressure changes

TESTING

TCSC 1006/Figure 14

The frequency of occurrence of a range of acceleration values – 20' ISO freight container

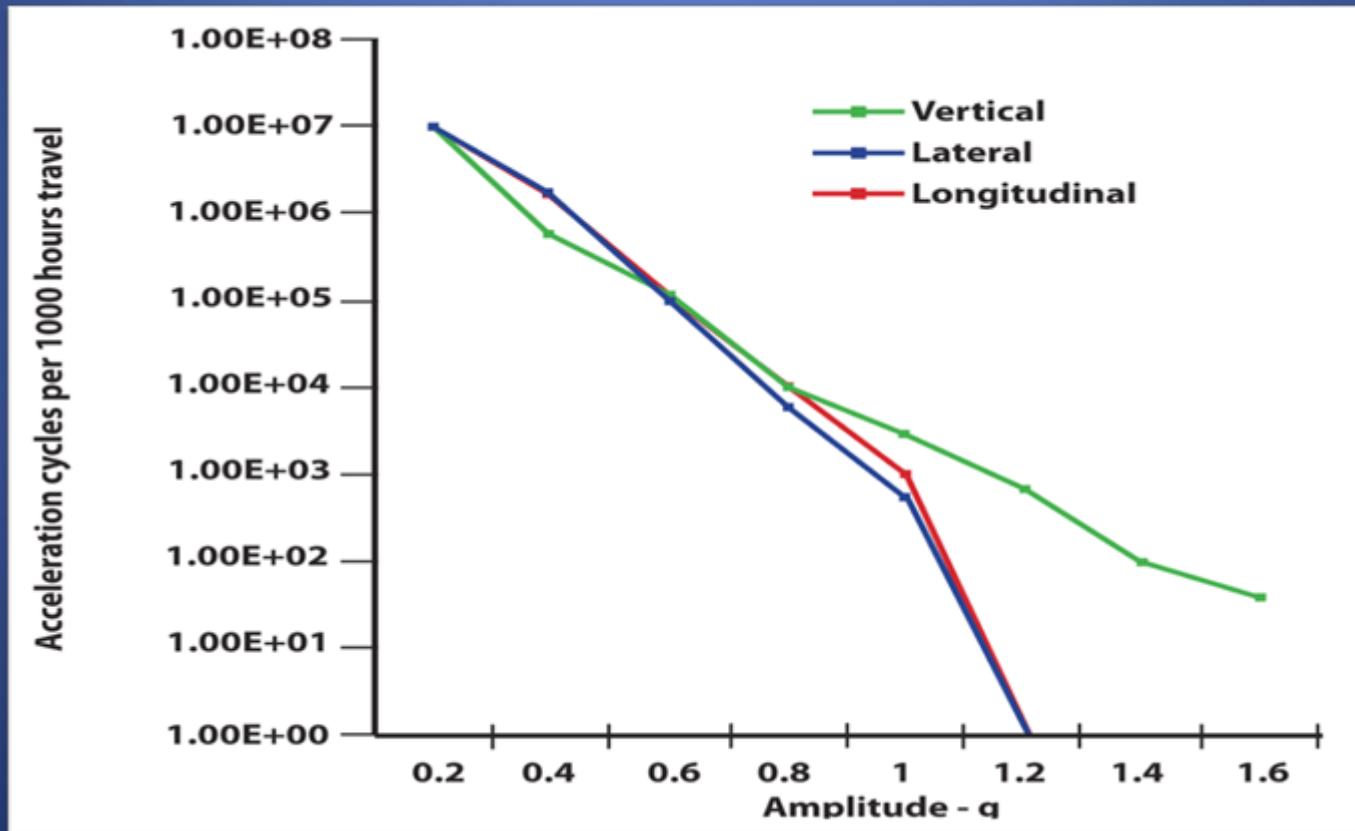

TESTING

TCSC 1006/Table 6 Load Case 3

Figure 14 - Acceleration data 20' ISO freight container

Load case	Longitudinal amplitude -g	Lateral amplitude -g	Vertical amplitude -g	Total number of cycles per 1000 hours
1	0.4	0.2	0.4	11.15×10^6
2	0.8	0.4	0.8	1.93×10^6
3	1.2	0.6	1.2	99.5×10^3
4	1.6	0.8	1.6	5.36×10^3
5	2.0	1.0	2.0	491

TESTING



- The soft sided package was tested to over 180 hours of simulated drive time with no dispersal of contents
- A fluorescein tracer dust was mixed in with the sand, soil and construction debris,

and at specific intervals during the test the bag was inspected using a fine mist water spray and UV light. No fluorescein dust was detected

CONCLUSION



- Testing and experience has proven that soft-sided packaging is a viable alternative for disposal of VLLW
- With the large volumes and variety of wastes anticipated in

the UK, there is room for more than one waste package design

- Soft sided waste packages and HHISO containers are expected to be used for years to come, depending on best fit for each packaging application