



Comparison of Analytical and Physical Testing Results for the DPP-2 Shipping Package

Matthew R. Feldman
Oak Ridge National Laboratory, Oak Ridge, Tennessee, U.S.A.

Kim D. Handy
Y-12 National Security Complex, Oak Ridge, Tennessee, U.S.A.

Contributing: Paul T. Singley, Rick D. Michelhaugh, Mark B. Hawk and Larry B. Shappert
Oak Ridge National Laboratory, Oak Ridge, Tennessee, U.S.A.

Overview of DPP-2 Shipping Package

The DPP-2 is a Type B fissile material shipping package developed by the Y-12 National Security Complex in Oak Ridge, Tennessee, in 2002–03. Currently, the DPP-2 is undergoing certification review by the Packaging Certification Division (PCD) of the National Nuclear Security Administration (NNSA) Service Center in Albuquerque, New Mexico, U.S.A. Issuance of an Offsite Transportation Certificate (OTC) for this package is expected in the near future.

The DPP-2 is a drum-type package and is approximately 28.7 in. tall and 24.7 in. in diameter, as shown in Fig. 1. The overpack is manufactured using a stainless steel drum as the starting point. A piece of formed angle iron is welded to the top of the drum to facilitate the attachment of both weld studs for drum-lid capture as well as an inner liner. The volume between the drum and the inner liner is an annular space filled with an inorganic impact-limiting and thermal-insulating material called Kaolite 1600™. The containment vessel (CV) is made of stainless steel and sits within the inner liner. The CV lid is attached to the CV body with 16 high-strength cap screws. Two elastomeric O-rings are used at the CV–lid interface; the inner one forms a portion of the containment boundary, and the outer one facilitates leak testing. Above the CV and within the inner liner is the removable top plug, which consists of a stainless steel shell and Kaolite 1600™ filling. A special feature of the DPP-2 design is the two metal hoops placed on the outside of the drum, one near the top and one near the bottom. The hoops help limit damage from crush tests that impact the side of the package (see Fig. 1). For this reason, the hoops are referred to as crush rings.

Kaolite 1600™, which is manufactured by Thermal Ceramics, is a mixture of portland cement and expanded vermiculite with a density of 20–26 lb/ft³. This material was originally developed as a refractory for high-temperature furnaces; therefore, it is able to withstand temperature extremes. Packages using Kaolite are basically fireproof, because Kaolite 1600™ is impervious to temperatures up to about 2300° F. It also possesses extremely good impact-limiting properties as it absorbs a tremendous amount of energy at impact before reaching lockup. Additionally, its ability to absorb energy is not significantly altered by either high or low temperature extremes typical of package use. The use of this material was pioneered by Y-12 on the ES-2/ES-2100 family of Type B Shipping Packages.

DPP-2 Design Process

Finite element analysis (FEA) is used extensively by Y-12 Engineering during the development of a shipping package. Proposed designs are studied using impact analysis during the initial design process. Typically, several design concepts are rendered and each one is modeled using FEA. Based on the results, one of the design concepts is chosen, or a hybrid of two or more of the design concepts is carried forward for further development.

Once a primary design has been chosen, FEA is used to evaluate that design's performance in many different structural aspects. The regulations in 10 CFR 71.73 require that specimens be tested in the most-damaging orientation; however, little guidance is provided as to how to determine this orientation. Therefore, during this phase of the development process, a determination must be made regarding what test orientation(s) will be used when prototype shipping packages are tested. Since the DPP-2 is a fissile material package that has a density <1000 kg/m³ and a total weight of less than 500 kg and may at some point be required to transport more than 1000 A₂s of material, it was required to undergo the crush test. It should be noted that the 1000 A₂ criterion will no longer be in effect in the U.S.A. for fissile material packages when the revised regulations take effect October 1,

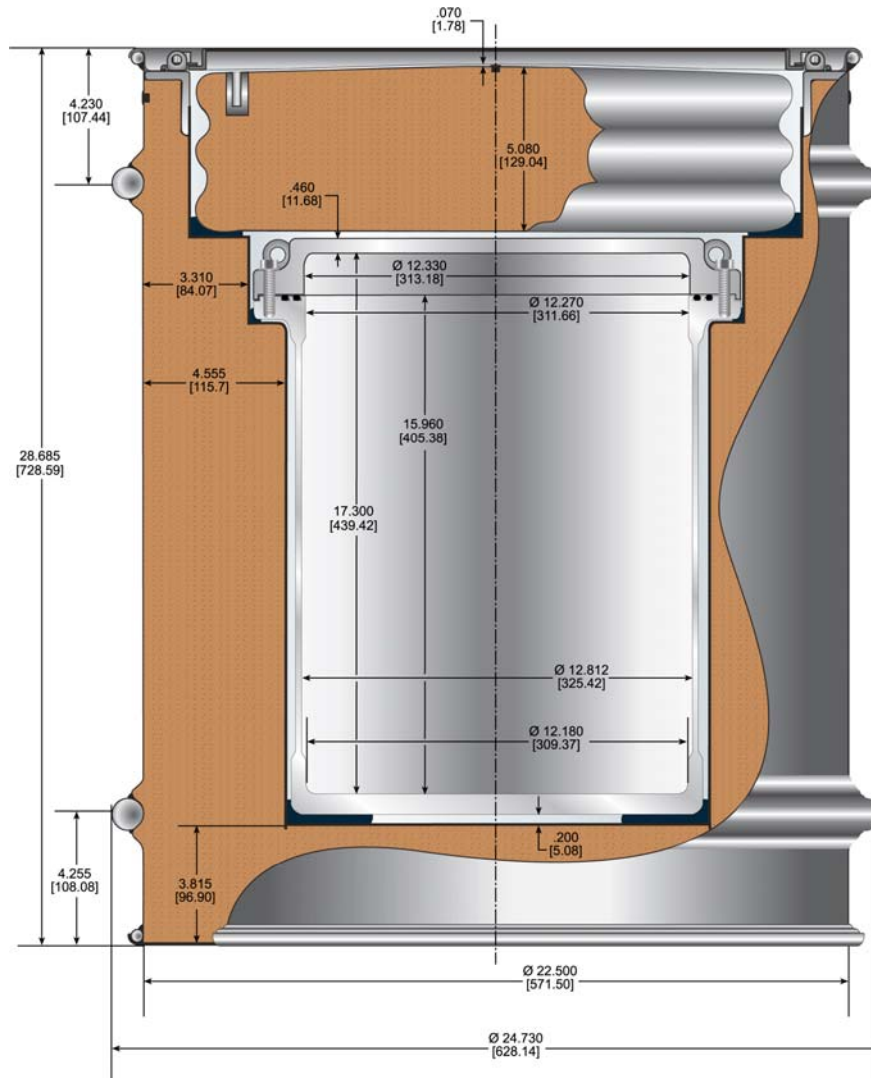

Figure 1. Cutaway view of the DPP-2 Shipping Package [dimensions are inches (millimeters)]

2004. This test consists of dropping a 1- x 1-m-square 500-kg steel plate from a height of 9 m onto the package as it rests on an unyielding surface. The U.S. regulations differ from those of the International Atomic Energy Agency (IAEA) in that each package tested must undergo both the 9-m drop and the 9-m crush tests (IAEA requires one or the other, whichever will cause the greatest damage.) Due to this requirement, it is necessary to use FEA to simulate the cumulative damage of the drop test followed by the crush test. That is, the drop test is first simulated, and the deformed shape resulting from the drop test is then subjected analytically to the crush test.

Y-12 Engineering has chosen to use exclusively the computer code LS-DYNA-3D for FEA of dynamic impact tests, such as the drop and crush tests discussed above, on shipping packages. In their experience, this code provides the most accurate representation of the nonlinear plastic deformations that occur in these types of tests when compared with other commercially available computer codes. The model of the DPP-2, which was constructed using the TrueGrid preprocessor, is shown in Fig. 2. Only half of the package was actually modeled, to take advantage of the plane of symmetry about the vertical axis of the package.

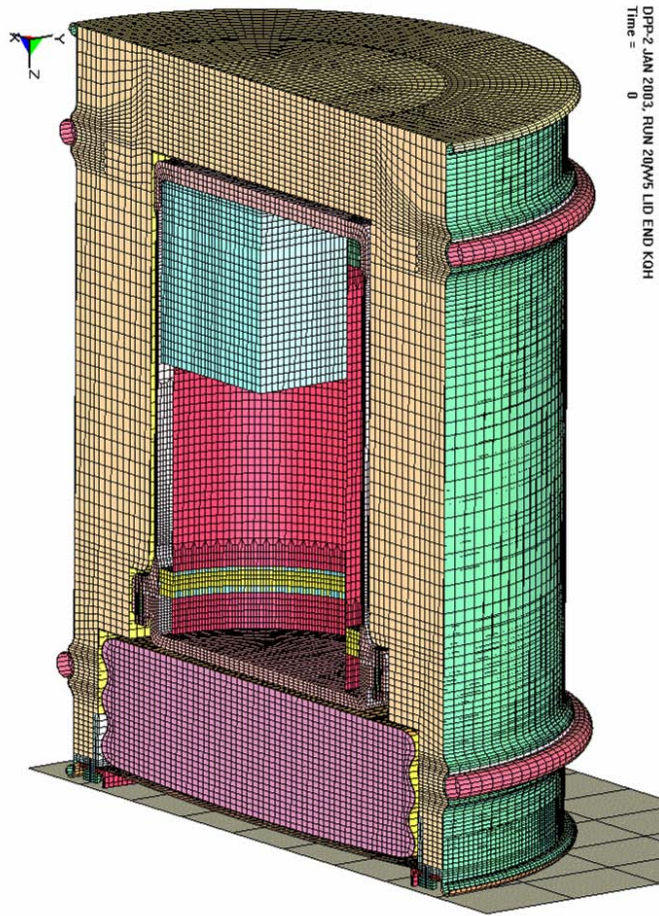

Figure 2. FEA model of DPP-2 Shipping Package

Testing Process

Once the design process was complete, prototype units were procured, prepared, and tested. The Transportation Technologies Group (TTG) at Oak Ridge National Laboratory (ORNL) performed the regulatory testing of the DPP-2 Shipping Package. TTG is located at the National Transportation Research Center (NTRC) in Knoxville, Tennessee, where they operate the Packaging Research Facility (PRF). Included within the PRF are facilities needed to perform all 10 CFR 71 tests, with the exception of the HAC thermal test. Thermal tests are performed off-site. Prior to the initiation of testing, a complete test plan was authored and signed off on by both ORNL and Y-12 personnel. The test plan delineates the test sequence for each test unit and prescribes the data recording requirements for each test performed.

Each of the six DPP-2 full-size prototype packages tested was subjected to NCT 1.2-m drop tests, HAC 9-m drop tests, 9-m crush tests, 1-m puncture tests, and 30-minute HAC thermal tests, in that order. One of these test units was also subjected to NCT water spray, compression, vibration, and penetration tests prior to the above-mentioned structural and thermal tests. Once testing was complete, the packages were exposed to a variety of leak tests including 3-ft immersion tests, pressure-drop O-ring leak tests, and full CV-boundary helium leak tests. The vast majority of structural deformation is caused by the 9-m drop and 9-m crush tests. The following paragraphs focus on these impacts.

The DPP-2 HAC 9-m drop and crush tests were performed at the outdoor drop pad at the PRF in August 2003 (Fig. 3). The setup for these tests included high-speed (500 frames per second) video cameras and stadia boards. After rigging in the proper orientation, a crane was used to hoist the package or the crush plate to the desired height prior to testing. A remotely controlled release mechanism was used to initiate the tests once all systems were ready for testing.



Figure 3. Preparations for crush testing of DPP-2 Shipping Package

The HAC 9-m drop tests were performed in four different orientations: (1) top down, (2) center of gravity (CG) over corner with lid down, (3) 12° slap down with drum bottom impacting first, and (4) horizontal side drop. Three units were tested in the side-drop orientation. Each of the packages was rigged at ground level, and the actual angle of each package was measured and compared with the intended angle specified in the test plan. While the test plan calls for actual orientations to be within $\pm 2^\circ$ of the intended angle, typical rigging renders angles within $\pm 0.5^\circ$ of intended. Packages are allowed to free-fall once released, which can lead to some minimal rotation prior to impact; however, review of the high-speed videotape indicated no significant rotation of the DPP-2 test units prior to impact.

With the exception of the 12° slap-down test unit, which was positioned in the horizontal orientation, the HAC 9-m crush tests performed with the packages positioned on the test pad in the same orientations used during the 9-m HAC drop test; top down, CG over corner, and horizontal. (Four units were crush tested in the horizontal position).

For each test, the crush plate was rigged in a horizontal orientation prior to release. Typically, the CG of the plate was centered over the CG of the package in an attempt to impart maximum energy from the plate to the package. For one of the crush tests, the CG of the plate was centered over the location of the flange of the containment vessel to determine if this was a vulnerability.

Before and after each of the structural tests, a full set of package measurements was taken, such that the deformations due to each test could be recorded (i.e., not just the cumulative damage caused by all tests). These data were carefully recorded and later included as part of the final test report.

Comparison of Analytical and Physical Testing Results

Since the results of FEA are used to determine worst-case orientations for actual drop testing as well as for general design changes prior to prototype production, it is important to verify that the modeling results predict the actual deformations that take place during testing. Generally, the best way to verify the results is to directly compare post-test dimensions of the prototypes with those of the FEA model. Because it is often hard to capture the total deformation through simple measurements, visual comparison of the analytical model and the actual test units is also beneficial. Both methods of comparison are presented below.

As discussed above, six DPP-2 units were tested in a total of four different orientations. In general, the agreement between the deformations that were predicted by the analytical model and those found on the actual prototype units was very good. For the purposes of this paper, two of the four orientations are discussed: (1) CG over corner and (2) horizontal. Due to the low aspect ratio of the package, results from the 12° slap-down drop tests followed by the horizontal crush test do not differ significantly enough from the horizontal drop tests and crushes to warrant discussion. Additionally, the top-down test yielded the least deformation of the various orientations and is therefore not discussed here.

CG-over-Corner Tests

DPP-2 Test Unit 2 was subjected to 1.2- and 9-m drop tests while initially suspended at the drop height in the CG-over-corner orientation (~37.7° from vertical). After these tests were complete, the package was placed on an unyielding surface oriented at this same angle (twine was used to balance the package in proper orientation), with the lid down. A 1- x 1-m square 500-kg plate was dropped from 9 m above the package such that the CG of the crush plate contacted the bottom edge of the package and projected through the CG of the package. Prior to testing, a similar scenario was modeled using FEA in which the HAC 9-m drop and 9-m crush test were simulated. The 1.2-m NCT drop was not included in the FEA sequence. However, damage from this orientation would be minimal, such that a comparison of the overall results is still plausible.

As expected, the DPP-2 showed significant exterior deformations after testing. Considerable folds were created at the top of the drum (due to the 1.2-m, 9-m, and crush test impacts). Figure 4 shows a view of the top of the DPP-2 package after these tests were performed. Figure 5 shows the deformations predicted by FEA after the same battery of tests. It is clear that the agreement is very good and that FEA has fully captured the essence of the actual tests. Both figures show a pronounced crease in the drum lid. This creasing is caused by the point of impact being forced downward toward the crush ring on the side of the drum. For Test Unit 2, the point of impact on the drum lid was measured to be 3.25 in. below the plane of the undamaged portion of the lid. FEA predicted this lid deformation to be 4.08 in. Overall drum heights of the tested unit were measured at 0°, 90°, 180°, and 270° around the circumference of the drum, with 0° being the point on initial impact. These deformations were also gleaned from FEA. FEA predicted heights of 24.7, 28.1, 23.1, and 28.1 in., whereas the test unit had measured heights of 25.0, 28.4, 23.1, and 28.2 at the 0°, 90°, 180°, and 270° positions, respectively. In both Figs. 4 and 5, the deformation shown is with the point of impact being very near to the crush ring. What separates the point of impact from the crush ring is the creased metal of the drum side wall between the lid and the crush ring. Note that Fig. 5 shows how well FEA captured the creasing of the drum side wall when compared with Fig. 4.



Figure 4. Top view of DPP-2 Test Unit 2 after CG-over-corner tests

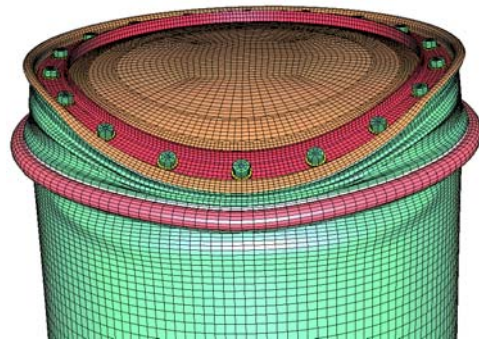

Figure 5. Top view of FEA model after simulated CG-over-corner tests

Similarly, deformations at the bottom of the package from the crush test were also accurately predicted by FEA. Figure 6 shows the bottom of the DPP-2 package after the CG-over-corner crush plate impact, and Fig. 7 shows the FEA result for this scenario. Again, there is excellent agreement between FEA results and the actual test results, including the characteristic folding of the metal of the drum side wall. The point of impact was deformed 5.7 in. during testing, while FEA predicted a deformation of 5.6 in.



Figure 6. Bottom view of DPP-2 Test Unit 2 after CG-over-corner tests

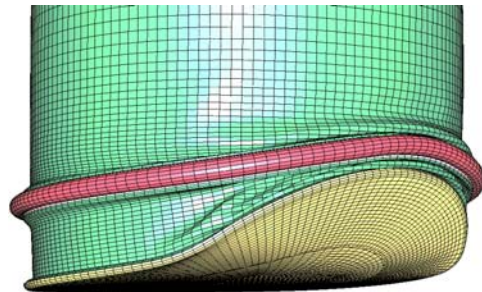

Figure 7. Bottom view of FEA model after simulated CG-over-corner tests

While all of the data discussed above agreed well with actual test results, the more remarkable feature was the manner in which FEA captured the actual deformed shape of the entire package body. This is best expressed visually by comparing Fig. 4 with Fig. 5 and Fig. 6 with Fig. 7. Through the choice of appropriate mechanical models coupled with careful detailed modeling, it can be seen that FEA is capable of accurately predicting final gross package deformations.

Horizontal Tests

DPP-2 Test Unit 4 was subjected to a horizontal drop in the same configuration as was modeled using FEA. When a drum-type package is horizontally drop tested, the typical result is “flattening” of the sides of the package. For comparison purposes, the width of these flats can be measured. Table 1 shows the predicted flats and the actual measured flats for this test unit. In general, the agreement is good, with FEA generally slightly over predicting the overall deformation. In Table 1 it can be seen that FEA predicted a symmetric response on the 180° side of the package from the drum top to the bottom false wire of the package. However, this was not seen in the tested unit, which had greater deformations toward the top (Note: The only test during which the 180° side was impacted was the 9-m crush test.). Review of videotape of this crush test reveals that the crush plate impacted the package at a slight angle, thereby causing the nonsymmetric response of the package. It must be remembered that during

Table 1. Comparison of test and analysis for predicted flattening after structural tests

| Length of Flattening at 0° | | Test Unit 4 | Analysis |
|------------------------------|-------------------|-------------|----------|
| | | Inches | |
| | Drum Top | 9.88 | 10.8 |
| | Top Crush Hoop | 11.38 | 12.9 |
| | CG | 4.5 | 6.9 |
| | Bottom Crush Hoop | 11.5 | 12.9 |
| | Bottom False Wire | 11.0 | 11.3 |
| Length of Flattening at 180° | | | |
| | Drum Top | 9.5 | 10.3 |
| | Top Crush Hoop | 10.75 | 11.8 |
| | CG | 4.12 | 4.9 |
| | Bottom Crush Hoop | 13.25 | 11.8 |
| | Bottom False Wire | 13.0 | 10.3 |

actual testing, exact impact points and angles may differ slightly from those anticipated, whereas with FEA, impact is always at the precise point and orientation intended. Another method of comparing overall deformation is to consider changes in the drum diameter. Table 2 shows the actual diameters compared with those predicted by FEA. In this case, the agreement is excellent. In both Tables 1 and 2, 0° is the side of the package that impacted first during the 1.2- and 9-m drop tests, and the 180° side of the package is that impacted by the crush plate.

Table 2. Comparison of test and analysis for predicted diameters after structural tests

| Diameter of Package 0° to 180° | | Undamaged | Test Unit 4 | Analysis |
|------------------------------------|-------------------|-----------|-------------|----------|
| | | Inches | | |
| | Drum Top | 23.6 | 20.9 | 20.6 |
| | Top Crush Hoop | 24.4 | 21.0 | 21.3 |
| | CG | 22.5 | 20.7 | 20.2 |
| | Bottom Crush Hoop | 24.4 | 20.5 | 20.7 |
| | Bottom False Wire | 23.4 | 20.0 | 20.8 |
| Diameter of Package 90° to 270° | | | | |
| | Drum Top | 23.6 | 24.1 | 24.2 |
| | Top Crush Hoop | 24.4 | 25.3 | 25.6 |
| | CG | 22.5 | 23.6 | 23.5 |
| | Bottom Crush Hoop | 24.4 | 25.4 | 25.2 |
| | Bottom False Wire | 23.4 | 23.6 | 23.7 |

Summary

FEA was used to simulate regulatory testing of the DPP-2 Shipping Package during its development. Once a final design was determined, full-size prototypes were built and tested. The results of both the analysis and the actual tests were compared. In general, these results were in good agreement. In cases where agreement between tests results was not as good, evidence indicated that the actual tests may have varied slightly from what was modeled using FEA. Moreover, close examination of the visual results from both the analysis and the testing indicates that FEA is correctly simulating the mechanics of the plastic strain that leads to the deformations observed in the units undergoing physical tests. Therefore, FEA has been shown to be an extremely useful tool during the development process for both design development and test orientation determination. Further refinement of the FEA process may one day help lead to virtual testing in place of physical regulatory testing or may at least enable certification of package designs with only a very modest physical testing program for confirmation.