

ANF-10: A New Transport Container for Fresh BWR Fuel Assemblies According to IAEA Requirements

W. Jahreiß
Framatome ANP GmbH
Bunsenstr. 43
D - 91058 Erlangen

U. Philippczyk
Advanced Nuclear Fuels GmbH
Am Seitenkanal 1
D - 49811 Lingen

W. Paulinyi
Advanced Nuclear Fuels GmbH
Am Seitenkanal 1
D - 49811 Lingen

J.-P. Masslowski
Federal Institute for Materials
Research and Testing
Unter den Eichen 87
D - 12205 Berlin

Introduction

The shipment of non-irradiated BWR uranium fuel assemblies (including enriched reprocessed uranium or ERU) as well as BWR and PWR fuel rods from the fabrication facility to power plants is performed using the new ANF-10 transport container. The ANF-10 container design fully meets the requirements of IAEA Safety Standards Series, No. TS-R-1 (ST-1, Revised) [1] for transportation by road, rail and sea.

On October 16, 2000, the German competent authority, the Federal Office for Radiation Protection (BfS) in Salzgitter, Germany issued the type IF package license for the ANF-10 shipping container. Since November 13, 2000 containers of this design have been used for shipping fuel assemblies and fuel rods within Germany as well as to Finland and Sweden. Applications for validation have already been submitted in Belgium, France, the Netherlands, Russia, Switzerland and Spain.

All drop and fire tests for the ANF-10 container were performed at the Federal Institute for Materials Research and Testing (BAM) in Berlin, Germany and its test site in Lehre, Germany.

Safety Requirements

The IAEA requirements [1], which are binding regulations throughout the world, require evidence for shipping containers for unirradiated fuel assemblies that such containers are capable of withstanding serious accidents without the release of radioactive substances or an unacceptable rise in reactivity. Such evidence can be provided on the basis of analysis, by analogy considerations or by tests on full-scale prototypes or on models. The evidence must essentially involve an imaginary accident sequence consisting of a drop from a height of 9 m onto an unyielding target, a drop onto a circular bar from a height of 1 m and a fire test of 30 minutes duration with a flame temperature of at least 800°C. These tests are preceded by verification that the container can also withstand the stresses from normal transport conditions (stacking test, penetration test and drop test from 1.2 m). The dropping positions of the containers must be chosen so that maximum damage is produced with regard to any effects on criticality safety.

ANF-10 Shipping Container

The ANF-10 shipping container comprises a bottom, a cover and a head cover with two guide tubes and two internal protection casings (see Figure 1). The container bottom, the cover and the head cover

are designed as “sandwich” structures with outer austenitic steel sheets on both sides and an aluminum honeycomb inside. The cover and the head cover are bolted to the container bottom.

Each BWR fuel assembly is enclosed in an internal protection casing, which is connected to the container bottom and made from boron austenitic steel plate. The cover of the internal protection casing is connected on one side to the bottom part of the internal protection casing by means of hinged joints. After closing the cover of the internal protection casing it is secured by means of retaining pins. The spaces between the internal protection casings and the container bottom, as well as the container cover, are filled with sections of polyethylene and foam material.

The axial free space of the various fuel assembly designs in relation to the internal protection casing is taken up by an appropriate bottom-end adapter. As a constituent part of the head cover, the top-end adapter secures the fuel assembly axially in the internal protection casing.

Depending on customer requirements, the fuel assemblies are shipped with or without fuel channel. In order to preclude direct contact with the boron steel internal protection casings during shipment, the spacers or fuel channels are fitted with plastic sleeves. As an option, the products can also be inserted in a polyethylene sleeve.

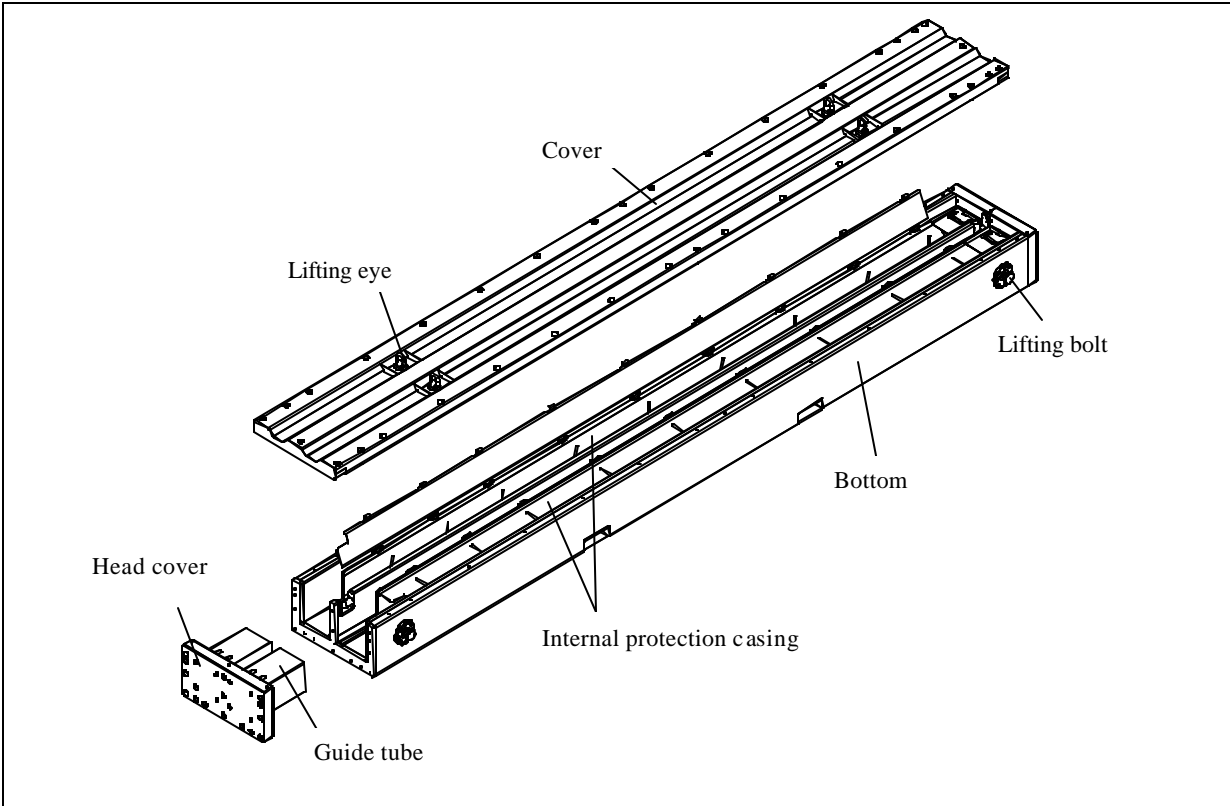

Fig. 1 ANF-10 Shipping Container

The following features characterize the ANF-10 shipping container (Fig. 2):

- IAEA requirements (Safety Standards Series No. TS-R-1), including the specified tests, are fully met.

- Loading with 5 wt.-% ^{235}U -enriched nuclear fuel with the theoretical pellet density is licensed both for ATRIUM fuel assemblies and for all typical BWR and PWR fuel rods currently in service.
- Criticality safety was conservatively demonstrated for a criticality safety index $\text{CSI} = 1$. Up to 50 containers (equivalent to 100 fuel assemblies) can consequently be transported and also stored as a unit.
- Depending on customer requirements, the fuel assemblies can be transported with or without fuel channels.
- Handling at the power plant is considerably simplified, since the previously-used wooden protective containers are no longer required.
- In terms of radiation protection, the smooth stainless steel surfaces are easy to survey and, if necessary, also easy to decontaminate.
- The dimensions (4725 mm x 668 mm x 362 mm) and gross weight (max. 1550 kg) of the ANF-10 shipping container ensure economic transport. A truck with a payload of 25 tonnes can transport 16 shipping containers packed with 32 fuel assemblies.
- The ANF-10 shipping containers handle and stack well. The container can be transferred using either a crane or a fork-lift truck.

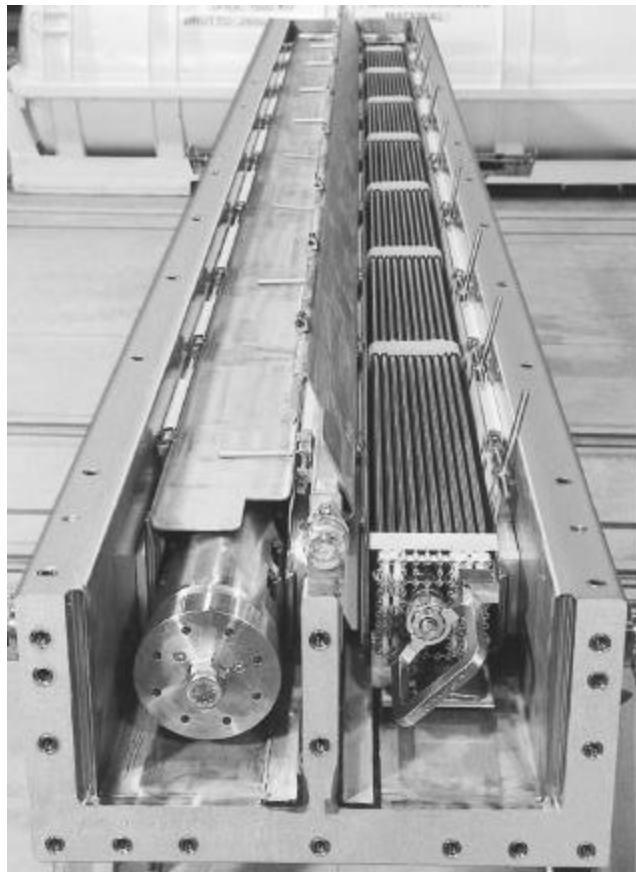

Fig. 2 ANF-10 Shipping Container loaded with a Fuel Rod Shipping Tube (left side) and a Fuel Assembly (right side)

Analytical Investigations

Development of the ANF-10 shipping container was accompanied by structural dynamics investigations using the DYNA-3D FEM code [2].

The computer simulations of drop tests according to IAEA specifications served on one hand to verify the state of development. Thus deficiencies could be detected at an early stage and design improvements could be made. On the other hand, the results of the analyses were used as a basis to identify and substantiate the "most damaging position" required by the IAEA for the drop tests (Fig. 3).

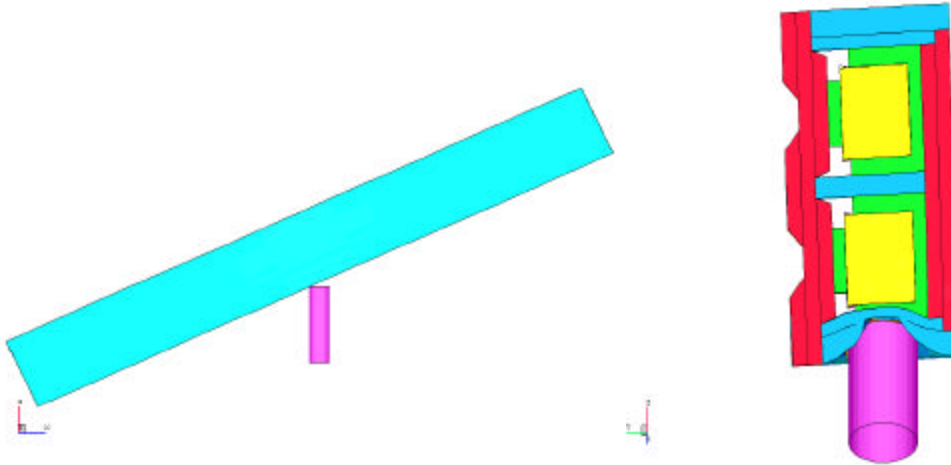

Fig. 3 ANF-10 Computer Simulation of Bar Drop Test

Tests for the ANF-10 Shipping Container

The mechanical tests detailed below were performed on a prototype. The container was loaded with two dummy assemblies which were identical to standard ATRIUM-10 fuel assemblies with the exception of the pellets (uranium dioxide was substituted with lead, which was found to be representative for the drop tests).

During the stacking test, the container was loaded for 24 hours with a weight exceeding five times the weight of a loaded container (8000 kg).

The penetration test was performed by dropping a 6-kg steel bar with a diameter of 3.2 cm from a height of 1.2 m onto the side wall of the container.

The drop-test sequence for the ANF-10 shipping container comprised the following:

- free drop of the container, with a longitudinal inclination of 15° , from a height of 1.3 m onto a side wall (Fig. 4);
- free drop of the container, with a longitudinal inclination of 15° , from a height of 9.65 m onto the same side wall; and
- dropping the container, with a longitudinal inclination of 25° , from a height of 1.1 m onto the bar. The bar was targeted to impact the container in line with the center of gravity on the same side as that impacted in the two previous tests.

The drop heights, which were increased slightly compared to the IAEA requirements, compensate the maximum gross weight.



Fig. 4 ANF-10 Drop Test from a Height of 1.3 m

Fire-resistance testing of the fuel rods was performed using representative dummy rod sections. The dummy rod sections, with a plenum region and molybdenum instead of uranium dioxide pellets (molybdenum being an acceptable substitute for thermal testing), as well as an enveloping helium internal pressure, were tested in the laboratory furnace under conservative IAEA conditions (800°C / 30 min). The insulating effect of the container was ignored.

Fire-resistance testing of the ANF-10 containers was performed using an ANF-10 test segment (shortened model of the full-scale ANF-10) at the BAM test facility in Lehre, Germany. To measure the actual temperatures in the container, the ANF-10 test segment underwent a 30 minute fire test (liquid-gas-fired open pool fire) at a mean flame temperature of approximately 950°C. The mean temperature at the surface of the container reached 900°C, while a maximum of 510°C was measured at the fuel rod positions. Figure 5 shows the test segment after the fire test.

The stacking test did not produce any measurable permanent deformation of the shipping container. The penetration test produced only a local indentation in the outer cover of the container bottom part. In the drop sequence (1.3-m free drop, 9.65-m free drop and 1.1-m bar drop), some bolts were broken in the container cover and head cover. However, the container cover and the head cover, remained securely connected to the container bottom. The container body exhibited local deformation at the points of impact with the foundation and bar.

Within the contour defined by the internal protection casings, the dummy rods and the spacers of the dummy assemblies exhibited some deformation, but significant grid widening or dummy rod breakage did not occur. No nicks or kinks were detected in the cladding tubes of the dummy rods as a result of the drop tests, and the leaktight enclosure was found to have remained intact.

In the thermal test with the representative dummy rod sections in the laboratory furnace at 800°C for 30 minutes, the diameter of the cladding increased by approximately 1.5 mm. No ballooning occurred, and the cladding tubes remained leaktight.

The thermal test with the ANF-10 test segment in the fire did not result in any significant deformation of the container structure. The maximum temperature at the fuel rod positions was 510°C. This demonstrated that the thermal test with the representative dummy rod sections (800°C / 30 minutes) was performed on the basis of very conservative assumptions.

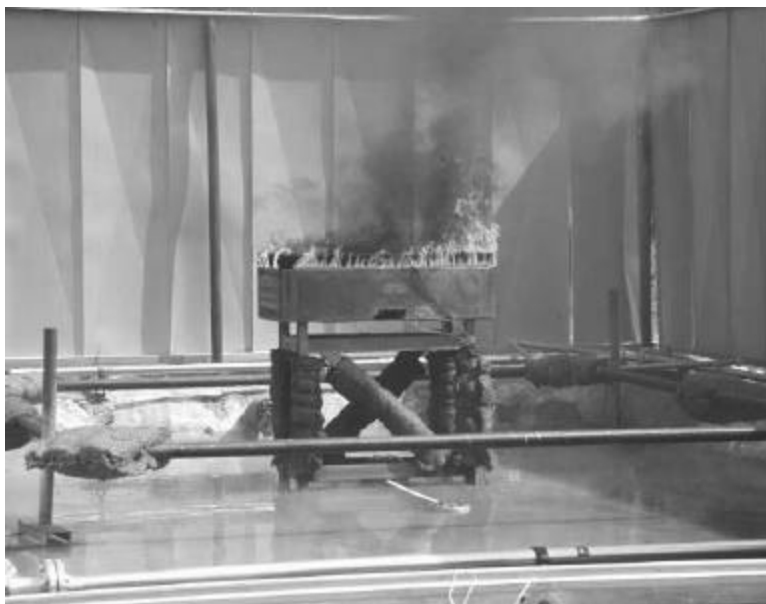

Fig. 5 ANF-10 Test Segment After Fire Test

Criticality Analyses for ANF-10 Shipping Containers

Criticality safety was demonstrated for ANF-10 shipping containers loaded with uranium fuel assemblies of the ATRIUM 9 and ATRIUM 10 designs, as well as for BWR and PWR fuel rods inserted in shipping tubes, using the program system SCALE-4.4a [3]. In every case, a maximum ^{235}U enrichment of 5.05 wt.-% (nominal value plus 0.05 wt.-% tolerance) and a theoretical pellet density of 10.96 g/cm³ were assumed for the nuclear fuel. Neutron poisons capable of being burnt off (e. g. gadolinium) were conservatively ignored.

In the criticality analyses it was shown that, with an enveloping consideration of the effects of the IAEA test sequence with a criticality safety index $\text{CSI} = 1$ (10 x 10 x 1 array of damaged containers), this container meets the relevant IAEA requirements. The design limit $k_{\text{eff}} \leq 0.95$ is fully met.

References

- [1] Regulations for the Safe Transport of Radioactive Material, 1996 Edition (Revised) Safety Standards Series No. TS-R-1 (ST-1, Revised) Requirements, IAEA, Vienna 2000
- [2] DYNA-3D: A Nonlinear, Explicit, Three-Dimensional Finite Element Code for Solid and Structural Mechanics-User Manual, University of California, Lawrence Livermore National Laboratory, UCID Report, UCRL-MA-107254 Rev. 1, 1993
- [3] SCALE 4.4a: Modular Code System for Performing Standardized Computer Analyses for Licensing Evaluation for Workstations and Personal Computers NUREG/CR-0200, Rev. 6; NUREG/CR-6182, Vol. 1; ORNL/NUREG/CSD-2/R6 V. 1-3; ORNL/TM-12663/V1, 2000