

## GUIDANCE AND METHODS FOR SATISFYING LOW SPECIFIC ACTIVITY MATERIAL AND SURFACE CONTAMINATED OBJECT REGULATORY REQUIREMENTS\*

R. B. Pope(1), L. B. Shappert (1), R. D. Michelhaugh (1), R. W. Boyle (2),  
E. P. Easton (3), and J. R. Cook (3)

- (1) Oak Ridge National Laboratory, P. O. Box 2008, MS-6495, Oak Ridge, TN 37831-6495, USA  
(2) United States Department of Transportation, Washington, D.C., 20590, USA  
(3) United States Nuclear Regulatory Commission, Washington, D.C., 20555-0001, USA

### SUMMARY

The U.S. Department of Transportation (DOT) and the U.S. Nuclear Regulatory Commission (NRC) have prepared a comprehensive set of draft guidance for shippers and inspectors to use when applying the newly imposed regulatory requirements for low specific activity (LSA) material and surface contaminated objects (SCOs). These requirements represent significant departures in some areas from the manner in which these materials and objects were regulated by the earlier versions of the regulations. The proper interpretation and application of the regulatory criteria can require a fairly complex set of decisions be made.

To assist those trying to apply these regulatory requirements, a detailed set of logic-flow diagrams representing decisions related to multiple factors were prepared and included in the draft report for comment on *Categorizing and Transporting Low Specific Activity Materials and Surface Contaminated Objects*, (DOT/NRC, 1997). These logic-flow diagrams, as developed, are specific to the U.S. regulations, but were readily adaptable to the IAEA regulations. The diagrams have been modified accordingly and tied directly to specific paragraphs in IAEA Safety Series No. 6. This paper provides the logic-flow diagrams adapted to the IAEA regulations, and demonstrates how these diagrams can be used to assist consignors and inspectors in assessing compliance of shipments with the LSA material and SCO regulatory requirements.

### INTRODUCTION

During 1996 and 1997, DOT and NRC, with assistance from personnel at the Oak Ridge National Laboratory (ORNL) and its subcontractors, prepared a comprehensive set of draft guidance for shippers and inspectors to use when applying the newly imposed regulatory requirements for LSA material and SCOs. This draft guidance (DOT and NRC, 1997) was developed based upon the requirements for LSA materials and SCOs in the U.S. domestic regulations (49 CFR Part 173 and 10 CFR part 71), which are, in turn, based on the international transportation regulations (IAEA, 1990a).

\* Managed by Lockheed Martin Energy Research Corp. for the U.S. Department of Energy under contract DE-AC05-96OR22464.

Since the regulatory requirements for LSA material and SCOs represent significant departures in some areas from the manner in which these materials and objects were regulated by the earlier editions of the regulations, the proper interpretation and application of these requirements can require a fairly complex set of decisions to be made. The requirements appear in various locations within the regulations, and complex decisions must be made as to whether a material, object, or collection of objects can be categorized for transport as LSA material or as SCOs.

To assist those trying to apply the new regulatory requirements, a set of detailed logic-flow diagrams representing decisions related to multiple factors have been prepared. Initially, these diagrams were prepared for the U.S. domestic regulations, and were then adapted to the IAEA regulations and tied directly to specific paragraphs in Safety Series No. 6 (IAEA, 1990a). These diagrams are presented and discussed in this paper. The factors addressed in the logic diagrams include demonstrating compliance with requirements for:

- specific activity levels;
- external radiation levels at 3 m from the unshielded surface;
- material form (i.e., solid, liquid, or gas);
- conveyance limits;
- whether a solid object is activated or not (i.e., used in determining whether a solid object might qualify as an SCO);
- whether a nonradioactive object satisfies the SCO contamination limits for accessible and inaccessible surfaces;
- whether a potential LSA material has its radioactivity distributed throughout or essentially uniformly distributed, which is used to indicate satisfaction of various LSA material requirements; and
- whether the material is relatively insoluble in water, which may be required to determine satisfaction with LSA-III requirements.

### **LOGIC-FLOW DIAGRAMS FOR CHARACTERIZING LSA MATERIALS AND SCOs**

The detailed logic-flow diagrams, which were derived from the regulatory text of the international regulations (IAEA, 1990a) for LSA material and SCO requirements, are presented in Figs. 1 through 6. The diagrams can be used by consignors in preparing shipments, and by auditors and inspectors to facilitate their efforts in overseeing compliance with the regulations. The user starts with specific characteristics of a material or object and proceeds toward determining whether that material or object may qualify for shipment as LSA material or SCO. The logic-flow diagrams are structured using:

- a "diamond"—Each diamond contains a question to be answered either "yes" or "no." Since the text of the questions in the diamonds have often been abbreviated to facilitate producing the diagrams, it does not replicate the actual regulatory text. Thus, the user should refer to the specific regulatory text and the associated explanatory and advisory text provided in Safety Series No. 7 and Safety Series No.37, respectively (IAEA, 1990b; IAEA, 1990c).
- a "double box"—The double boxes are located at the lower side of each "diamond," as appropriate, and provide the regulatory reference (i.e., paragraph number or table number from Safety Series No. 6) from which the question was derived.

- a "solid box"—The solid boxes represent outcomes of answering the questions in the logic diagrams (i.e., results, determining whether the material or object may be categorized as LSA material or SCO).
- a "circle"—The circles are node points identifying transfer between the figures of the logic diagrams.

In addition, small circles are located on each question identifier "diamond"; these circles are used to facilitate discussion of the logic process.

Fig. 1 presents the initial steps of the categorization logic-flow.

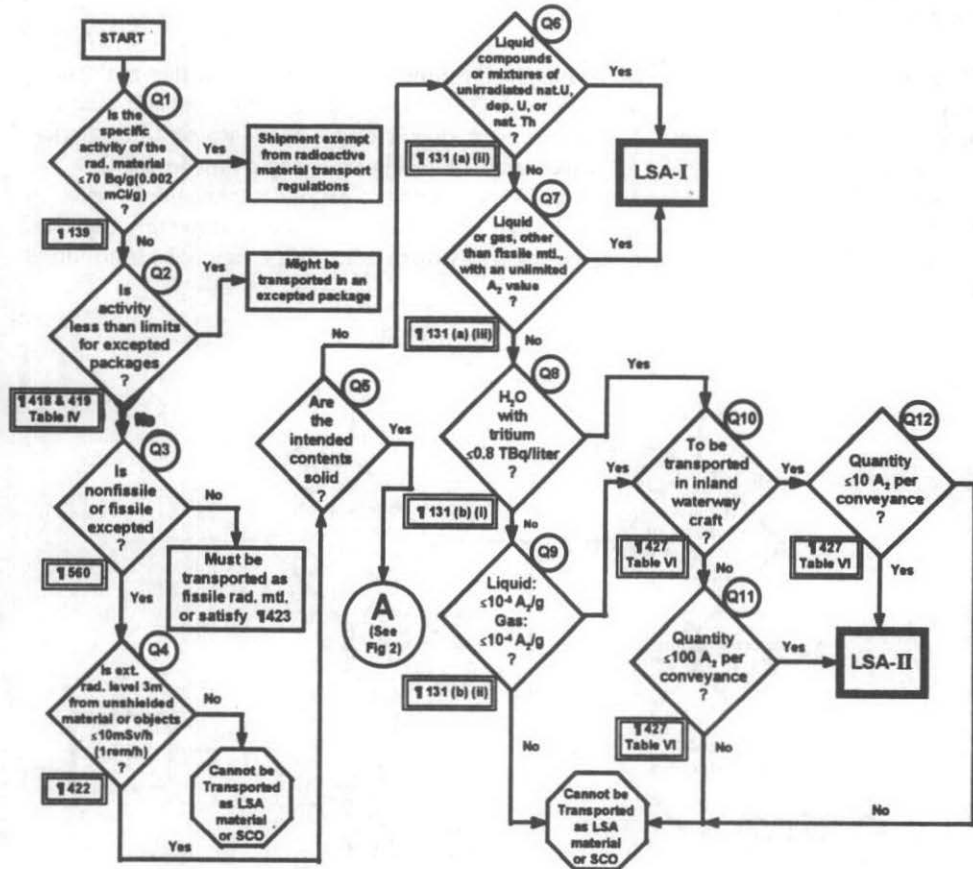

Fig. 1. Logic-flow for determining possibility for categorizing materials and objects as either LSA material or SCOs for screening for categorization of liquids and gases as LSA-I material or liquids as LSA-II material.

Progressing through the four questions shown on the left side of the figure (i.e., Q1 through Q4), one determines whether a more detailed characterization assessment as LSA material or SCO is warranted. For example, if the material or object can satisfy the requirements for limited quantity, it may be possible to ship under provisions of paragraphs 418 and 419 of Safety Series No. 6 allowing exceptions to regulations for packaging and transportation, and

no further effort may be needed. Alternatively, if the material or object is fissile or does not satisfy the 3 m radiation level requirement of paragraph 422 of Safety Series No. 6, then it cannot be packaged and transported in accordance with provisions for LSA material or SCO; further efforts to categorize it as LSA material or SCO would not be fruitful, and further actions will be required.

It is noted that a negative answer to Q3 results in two options, (1) a simplified and conservative approach to handling fissile materials or (2) transporting the fissile LSA material and SCO in compliance with paragraph 423. This latter option requires that (a) the storage in transit requires relating to the Transport Indexes are satisfied according to paragraphs 479 and 480 and (b) the package is designed and certified as a package containing fissile material (e.g., see paragraph 559 of Safety Series No. 6).

If the material or object successfully passes the Q1 through Q4 tests, then further evaluation may be undertaken using questions Q5 through Q12. The logic here addresses liquids and gases. If the intended contents of a package are not liquid or gas, then the user of the logic-flow is directed immediately to "A," which is the beginning of the logic-flow in Fig. 2. However, if the intended contents of a package are liquid or gas, a determination whether they can be transported as LSA-I material or LSA-II material can be made by answering questions Q6 through Q12. If the liquid or gas cannot satisfy these tests, then it cannot be transported as LSA material.

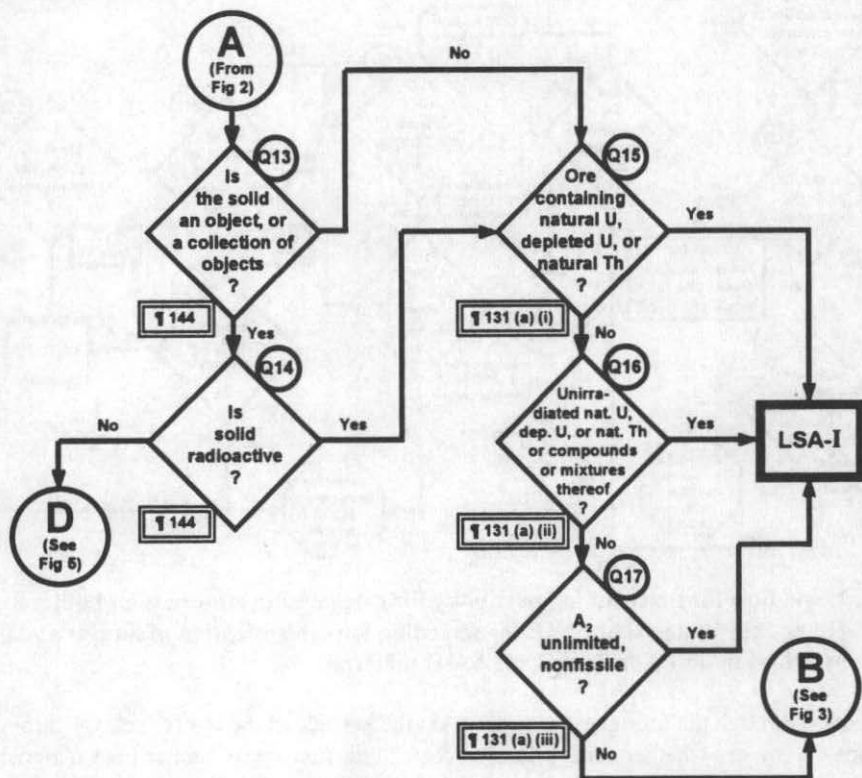

Fig. 2. Logic-flow for determining categorization of solid materials as LSA-I material.

The Fig. 2 logic-flow first determines, for solids, whether screening as SCO or as LSA material should be pursued. In the event that screening as SCO appears possible, the user of the logic-flow is directed to "D," which is the beginning point for the logic-flow in Fig. 5. However, for solids which can clearly not qualify as SCO as established by Q13 and Q14, the user then proceeds to assess whether the solids may qualify as LSA material. First, three separate tests (Q15, Q16, and Q17) are used to determine whether the material qualifies as LSA-I material. In the event that the material does not qualify as LSA-I, the user is directed to "B," which is the beginning of the Fig. 3 logic-flow.

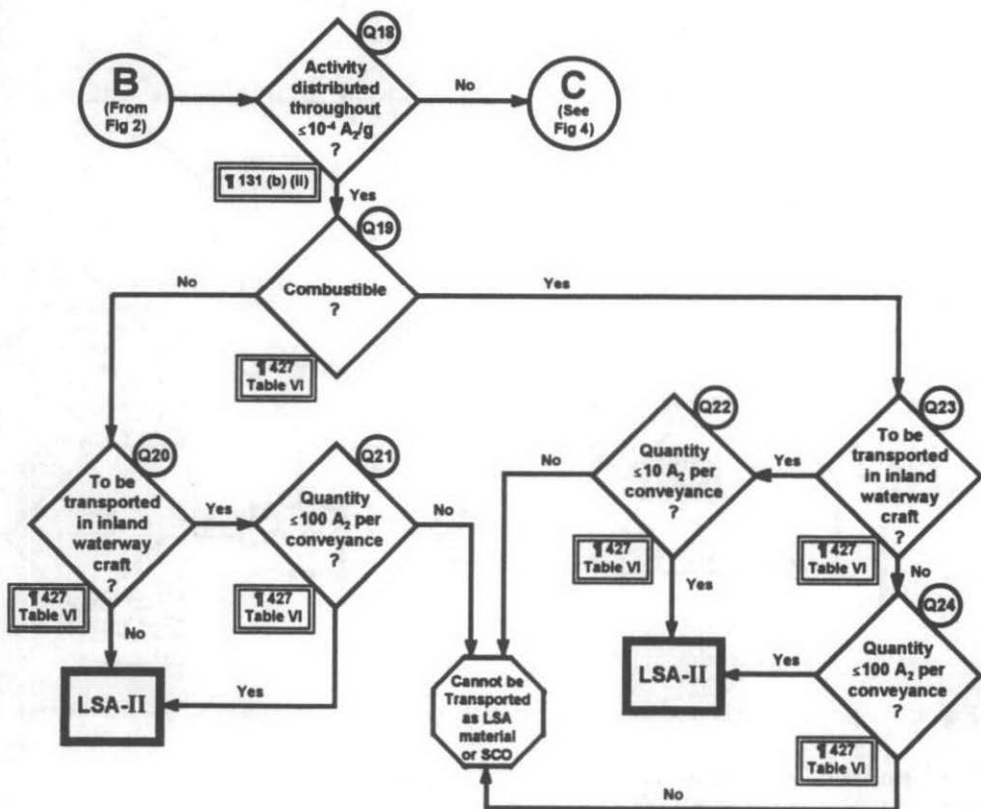

Fig. 3. Logic-flow for determining categorization of solid materials as LSA-II material.

In Fig. 3, the user addresses Q18 which quickly defines whether the material may qualify as LSA-II or whether qualification as LSA-III should be considered. In the latter case, the user is immediately directed to "C," which is the beginning of Fig. 4; otherwise, the user addresses six tests (Q19 through Q24) to determine whether a material can qualify as LSA-II. If the material does not qualify as LSA-II, the user has determined that it cannot be transported as either LSA material or SCO.

In Fig. 4, the user addresses Q25 through Q34 to determine whether a material can qualify as LSA-III. If the material does not qualify as LSA-III, the user has determined that it cannot be transported as either LSA material or SCO.

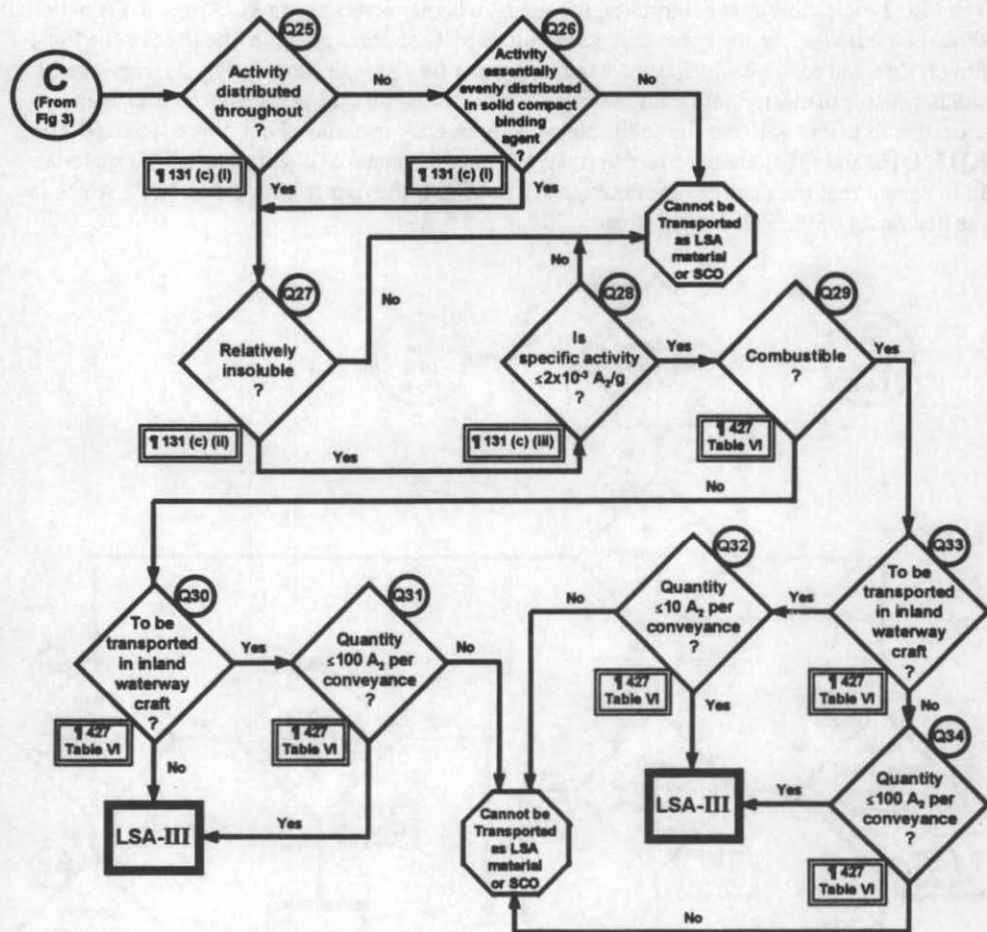

Fig. 4. Logic-flow for determining categorization of solid materials as LSA-III material.

The logic at the beginning of Fig. 2 may have directed the user to evaluate whether the material (which, in this case, is an object or collection of objects) might be qualified as SCO and the user may have been directed to "D," which is the beginning of Fig. 5.

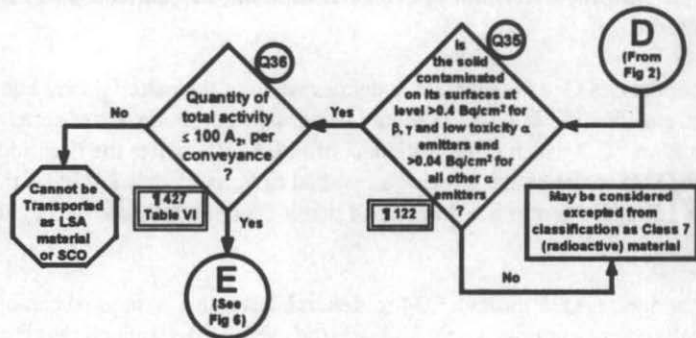

Fig. 5. Logic-flow for initiating screening of objects as SCOs.

Here, Q35 is used to determine whether the contamination is low enough to allow the object (or objects) to be excluded from being classified as an SCO, while Q36 quickly addresses whether shipment as SCO is possible by considering the maximum conveyance activity limit. If the object passes these two tests, detailed screening as SCO is then pursued using Fig. 6.

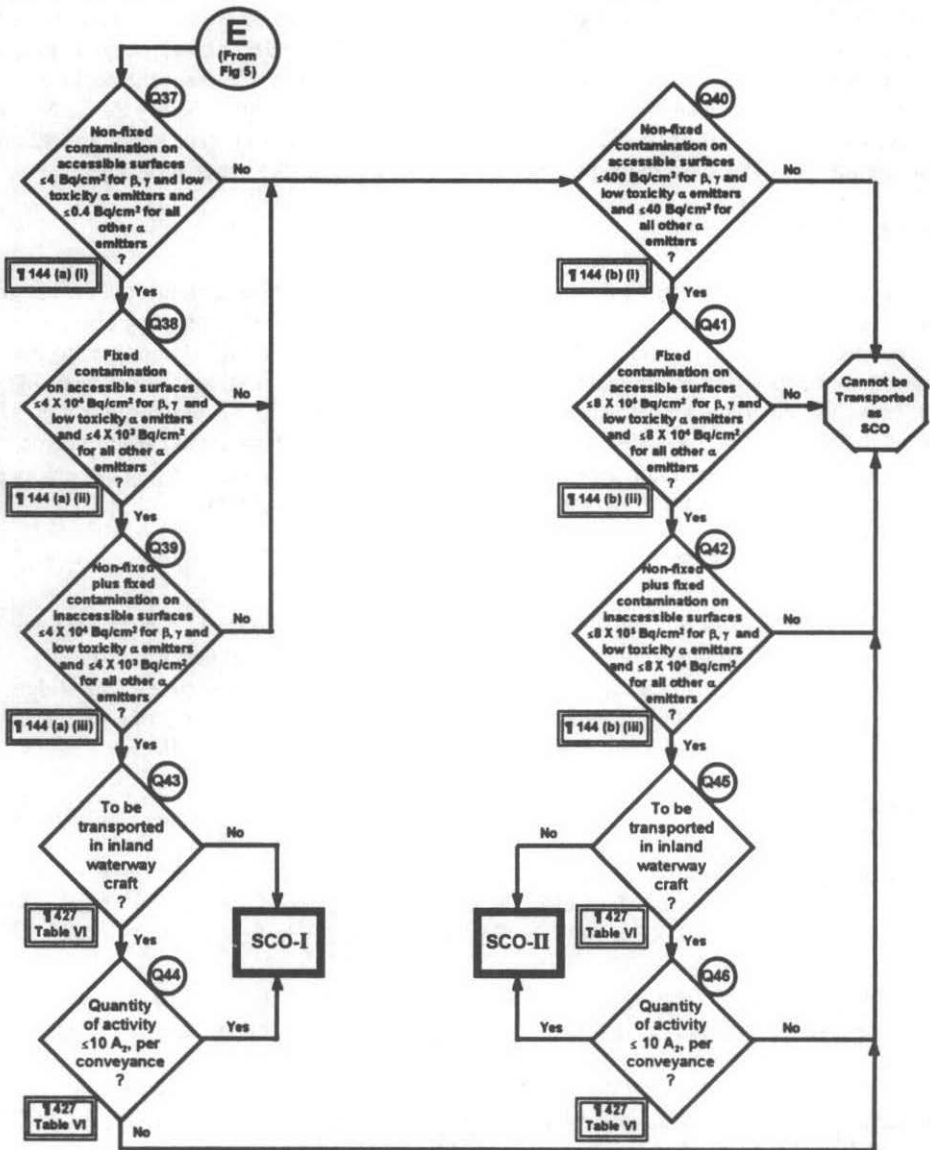

Fig. 6. Logic-flow for determining categorization of solid objects SCOs.

In this last figure, Q37 through Q46 are used to determine whether the object (or objects) can be categorized as SCO-I or SCO-II. Failing these tests, the user will have determined that it cannot be transported as SCO and may want to then assess whether the object (or objects) can be categorized as LSA material using the logic-flows in Figs. 2 through 4.

## REQUIREMENTS, CONTROLS, AND SELECTING PACKAGING OPTIONS

Once the appropriate categorization of the material or object has been reached using this process—i.e., the material or object has been successfully categorized as LSA-I, LSA-II, LSA-III, SCO-I or SCO-II—then the user may employ Table V of Safety Series No. 6—and paragraph 423 if the material or object is fissile (IAEA, 1990a)—to determine the minimum package design requirements for the LSA material or SCO. This selection will depend upon whether the shipment is to be made under exclusive use (where, in some cases the package requirements are less demanding) or not under exclusive use. In addition, Safety Series No. 6 provides for the transport of LSA-I and SCO-I in an “unpacked” state (see paragraph 425 of Safety Series No. 6) to assist in identifying packaging options for the material or object.

## CONCLUSION

The logic-flow diagrams and discussion presented in this paper provide a useful tool for better understanding the complexity of the decisions a consignor must make in preparing a shipment of material or objects as LSA material or SCO. The diagrams offer a logical approach to the many requirements which are embedded within Safety Series No. 6 relative to these types of shipments. The diagrams accompanied by the discussion can serve as a useful tool for (a) training personnel on LSA material and SCO categorization and packaging requirements, (b) enhancing compliance by consignors with these requirements, and (c) assisting inspectors in evaluating compliance with the international regulations for such shipments.

## ACKNOWLEDGMENTS

The authors wish to thank a number of people who contributed to the initial, United States-specific logic-flow diagrams, and to the development of the international version of these diagrams. These include J. Goss and S. Schurman of H&R Technical Associates, Oak Ridge, TN, USA; S. Ludwig of ORNL, Oak Ridge, TN, USA; R. Best and S. Schmid of SAIC, Oak Ridge, TN, USA; and G. Sullivan and R. Tucker of SMS, Oak Ridge, TN, USA.

## REFERENCES

- Categorizing and Transporting Low Specific Activity Materials and Surface Contaminated Objects—Draft Report for Comment*, U.S. Department of Transportation and U.S. Nuclear Regulatory Commission, NUREG-1608 and RSPA Advisory Guidance 97-005 (1997).
- Regulations for the Safe Transport of Radioactive Material—1985 Edition (As Amended 1990)*, International Atomic Energy Agency, Safety Series No. 6, Vienna, Austria (1990a).
- Explanatory Material for the IAEA Regulations for the Safe Transport of Radioactive Material (1985 Edition)—Second Edition (As amended 1990)*, International Atomic Energy Agency, Safety Series No. 7, Vienna, Austria (1990b).
- Advisory Material for the IAEA Regulations for the Safe Transport of Radioactive Material (1985 Edition)—Third Edition (As amended 1990)*, International Atomic Energy Agency, Safety Series No. 37, Vienna, Austria (1990c).